

Duraklick

A brand of SOLTOP Energie GmbH

soltop
energie 

Mounting system

Roofprallel

Eco 0°

Assembly instruction

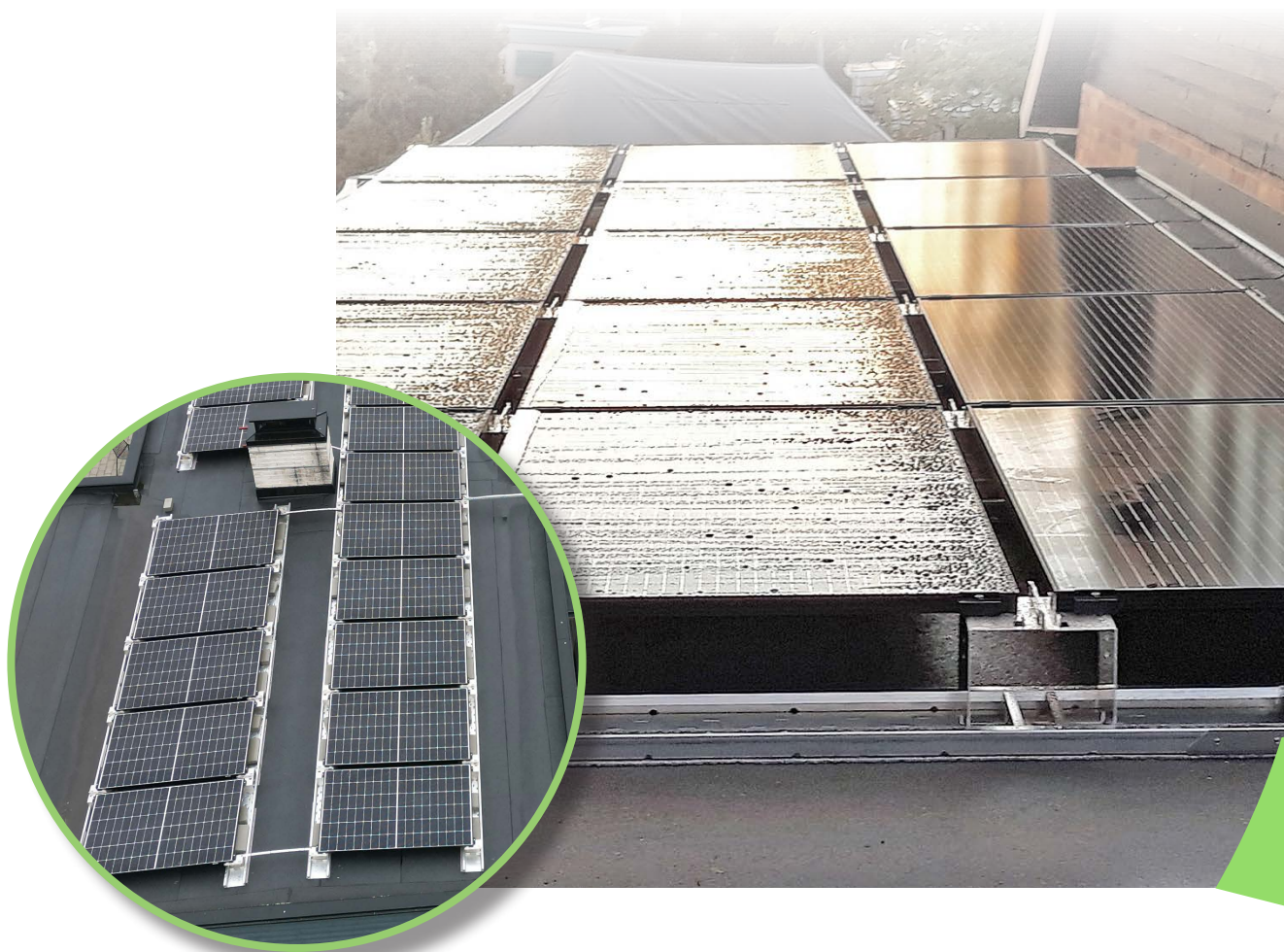

www.soltop-energie.eu

Welcome!

We are delighted that you have chosen the Duraklick-ECO mounting system. This guide explains the professional installation of the mounting system. If you have questions or suggestions, we will be happy to hear from you.

Your team
SOLTOP

The ECO 0° mounting system consists of the following components:

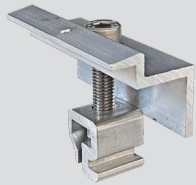

Module end clamp



Module center clamp



Module rail

Protection mat
(Minimum thickness 4 mm)



Module support
„Standard“



Two pieces make
one hooked into the other!



Optional:
Module support
“ECO 0° Optimal”

Mounting plate for supports,
from 10° roof pitch

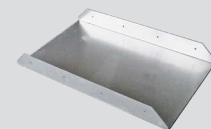
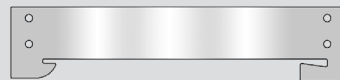

Connector profile



Self-tapping screws

For assembly you need:

- ▶ Cordless screwdriver
- ▶ Allen key 6 mm for the middle and end clamps
- ▶ 8 mm socket attachment for the self-tapping screws
- ▶ Measuring tape and tape measure
- ▶ Plastic hammer
- ▶ Gloves

Compliance with regulatory and safety standards

During installation of the assembly system, it is necessary to ensure compliance with safety regulations and precautions applicable in the respective country. In Germany these are:

Electrical installation::

- ▶ DIN VDE 0100-712 (IEC 60364-7-712) Low-voltage installations - Part 7-712: Requirements for premises, rooms and special installations - Solar photovoltaic (PV) power supply systems
- ▶ DIN VDE 0126 Solar systems for private use
- ▶ DIN EN 62305 Lightning protection
- ▶ VDEW guideline (2001)
- ▶ VDI 6012, Sheet 2, Decentralized energy systems in buildings - Photovoltaics
- ▶ TAB Technical connection conditions of the energy supply companies

Accident prevention regulations::

- ▶ BGV A1 Principles of prevention
- ▶ BGV A3 Electrical installations and operating equipment
- ▶ BGV C22 Construction work
- ▶ BetrSichV, supplementary "Instructions for handling ladders and steps" (BGI 694)

Other:

- ▶ VDS (Association of Property Insurers) guidelines
- ▶ DIN EN 1991-1-4 Wind loads
- ▶ DIN EN 1991-1-3 Snow loads
- ▶ DIN 1052 Design, calculation and dimensioning of timber structures - General design rules and design rules for building construction
- ▶ Current local provisions and regulations must be observed.

Photograph roof damage!

Before installation, check whether there is damage of any kind, in particular water beading or damage to the roof cladding.

These should be documented with a digital camera to avoid later claims for compensation.

Roof preparation

The roof surface to be covered must be free of impurities, e.g. sharp stones, moss, leaves, dirt, etc., to ensure that the floor rails can be laid flat. Clean the roof!



Caution!

Personal danger!

Module installation and laying of DC cables must be performed by expert personnel. (Danger of electric shock! Danger of arcing! etc.) If there are lightning protection systems already in place, have a specialist company check whether they may be integrated into the system. Also check for changes to lightning protection requirements as a result of the installation.

TIPP



Take photos of roof damage!



Clean the roof!



Wear gloves during assembly!
Risk of injury from sharp edges!

1. Mounting the module rail

1.1 Calibration

Take the installation plan to hand. Use the installation plan to measure the module field. Observe the distances according to the system statics.

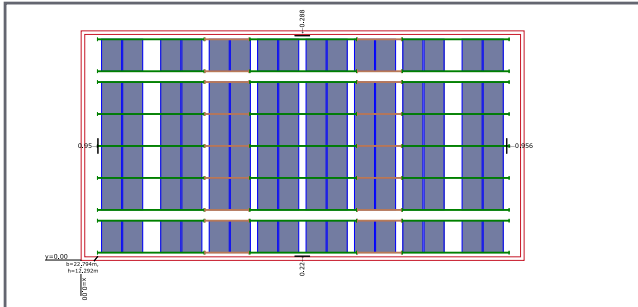

Calibrating the module fields

1.2 Laying building protection mats

Lay out the building protection mats at a distance from the floor rails. The axis dimension is always the module length plus 20 mm for the module center clamp.

For foil roofs (depending on the manufacturer), it must be checked whether fleece-laminated building protection mats need to be laid out.



Apply the protection mat

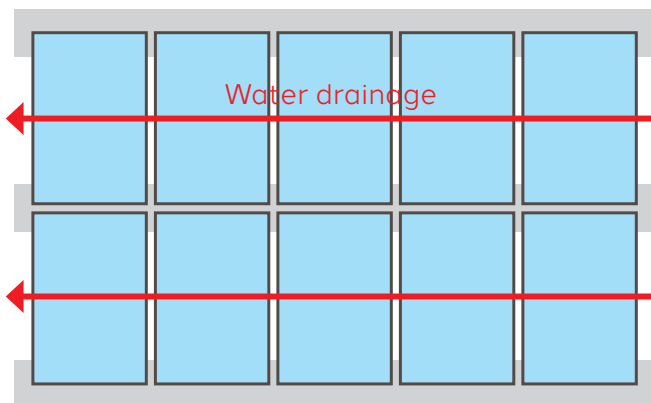

Protection mats (min. 4 mm) in rolls



For uneven roofs, we recommend gluing the building protection mats to the floor rails to prevent them from being washed away.

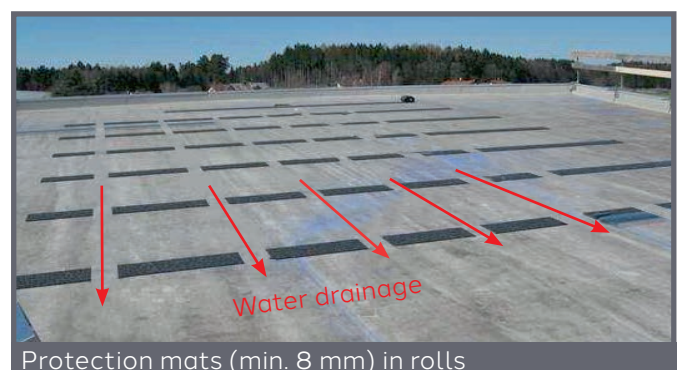

Protection mats (min. 8 mm) in rolls

1. Mounting the module rail



Apply module rail

1.3 Applying the module rail

Apply the module rail on the protection mat following the installation diagram.



Insert connector in the middle of the rail

1.4 Connecting the module rail

Insert the connector between the module rails.



Fasten the connector

Fasten the connector and the module rail using 8 self-tapping screws (tightening torque reference value indicated by manufacturer 2–3 Nm).



All other rails are arranged according to the design.

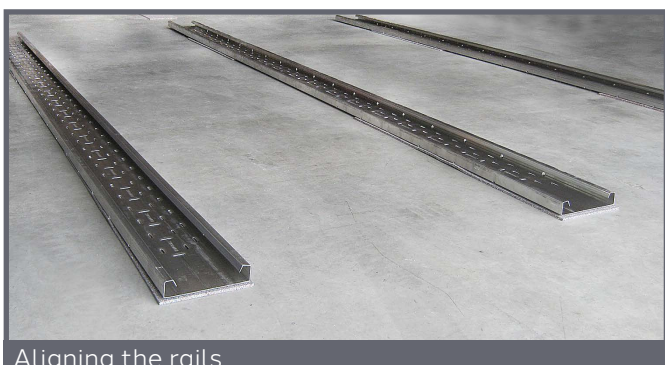

Aligning the rails

1.5 Adjustment and checks

Check the orientation of the module rail according to the installation plans. Check angle and parallelism of the rails.

2. Special solutions

2. Fixing with ballast:

Up to 5° roof pitch on bitumen roofs
Up to 3° roof pitch on PVC foil roofs
Our ballast calculations apply to flat roofs with a pitch of up to 5°. Steeply pitched roofs are special solutions whose fastening must be specified by the customer.

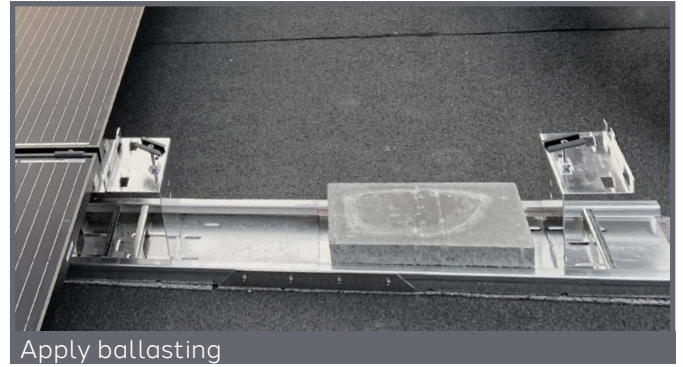

The following examples must be clarified by the customer and are as non-binding installation options.

2.1 Fastening with ground rail over the roof ridge

Above 5° roof pitch on bitumen roofs
Above 3° roof pitch on PVC foil roofs

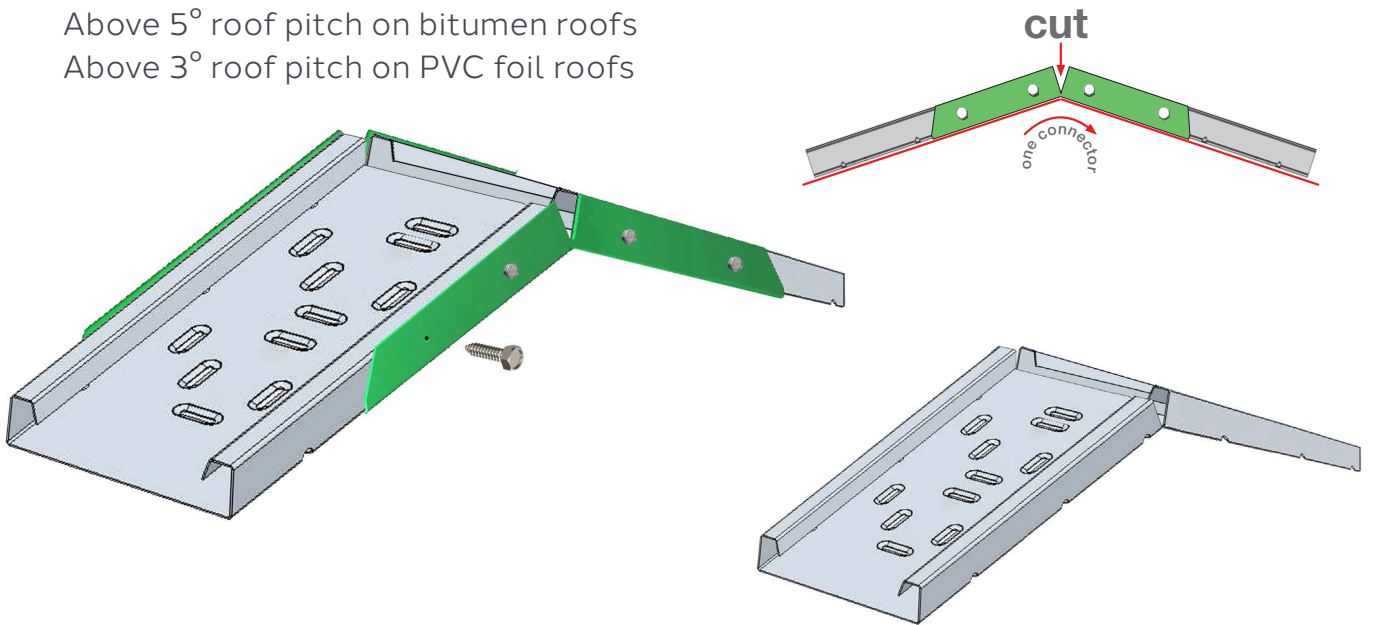

2.2 Fastening the floor rail with CWL panels

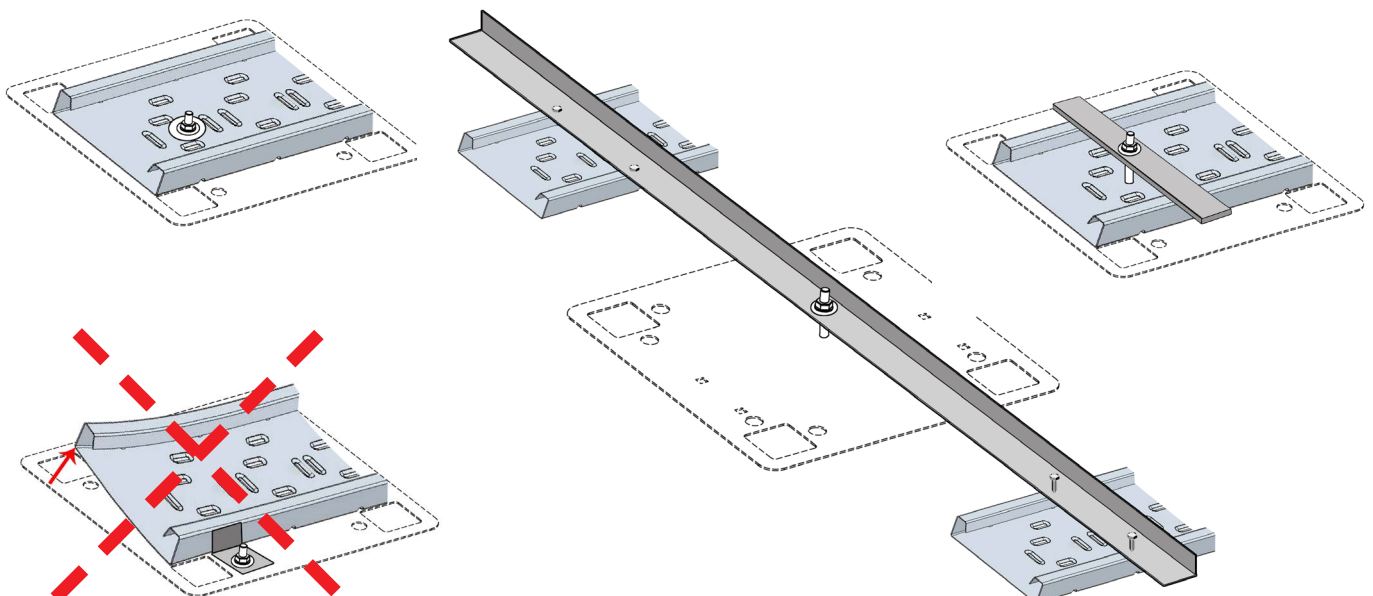

3. & 4. Special solutions

3. Anti-slip protection for pitched roofs

To prevent slipping on a pitched roof, the left and right sides of the system are connected with ropes via the ridge.

3a) Connect the ground rail to the ridge with the rope.

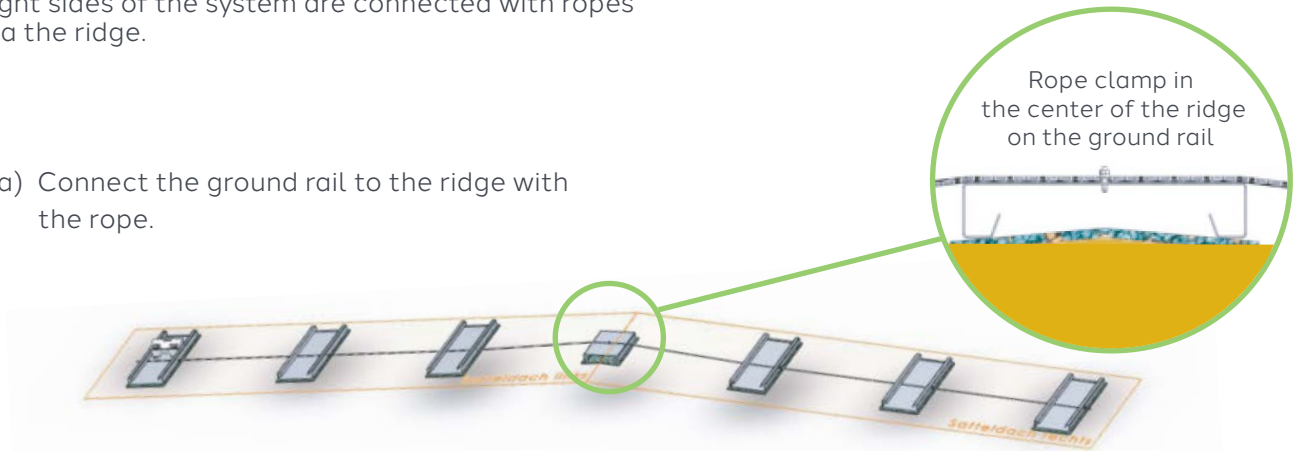

3b) Attach rope safety device in front of each row. Drill a hole with a diameter of 8 mm in both sides of the rails and deburr

Rope clamps

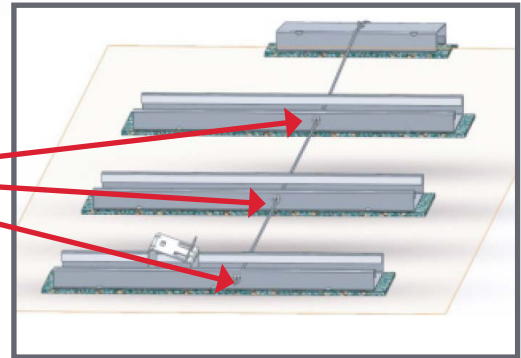

3c) Distance to the front module support max. 10 cm.

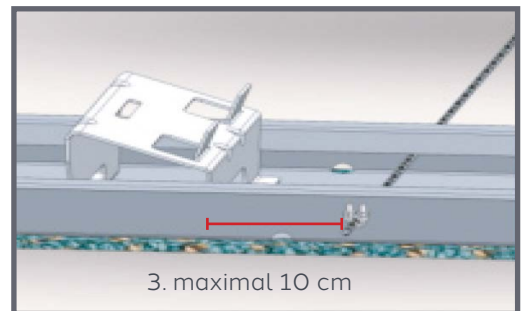

4. Anti-slip device for shed roofs

The attachment of the wire rope to the roof must be clarified on site:

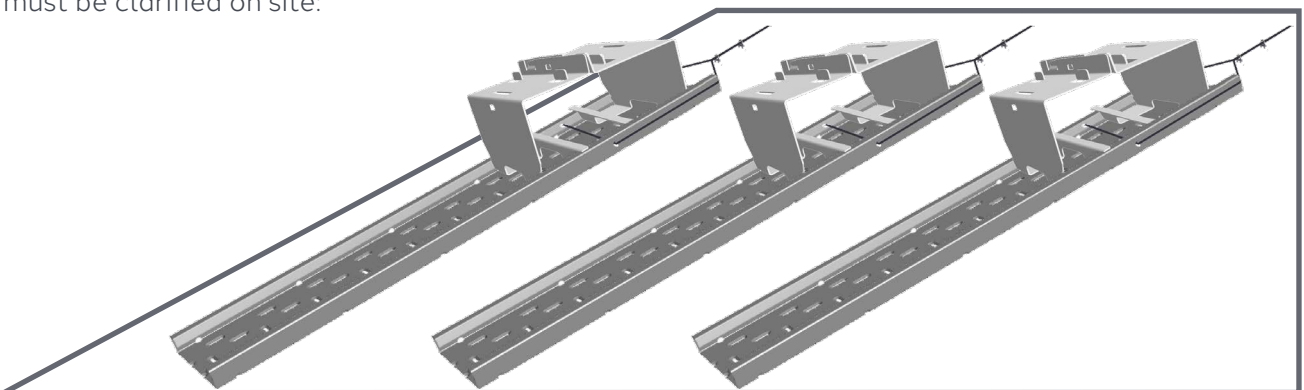

5. Mounting the supports „Standard“

5.1 Calibration



Calibrating the module support positions

Measure the positions of the module supports: The first and last support must be mounted at least 150 mm from the front edge of the floor rail.

5.2 Inserting the string cable



Floor rail used as a cable duct for the string cables

Attention: the floor rails can be used as a cable duct. The string cables should be laid before the module supports are clicked

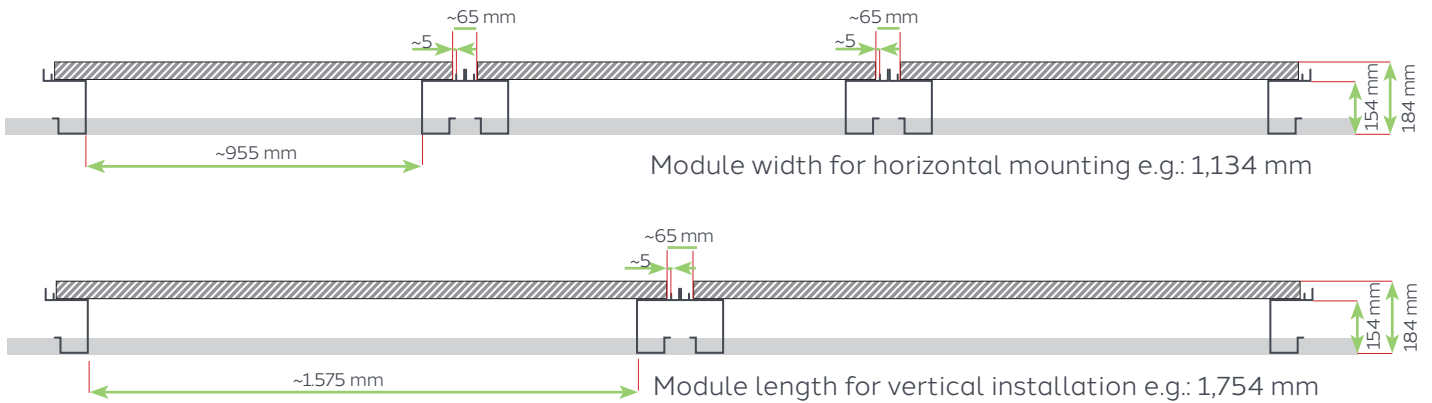

Distance dimension = module length/width minus 90 mm per side

Standard mounting

Horizontal

For low snow and wind loads. More cost-effective installation method.

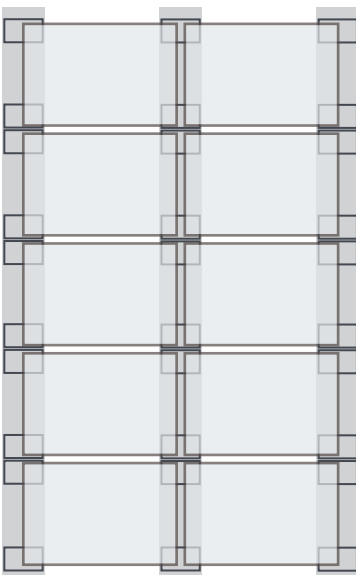

Standard mounting Vertical

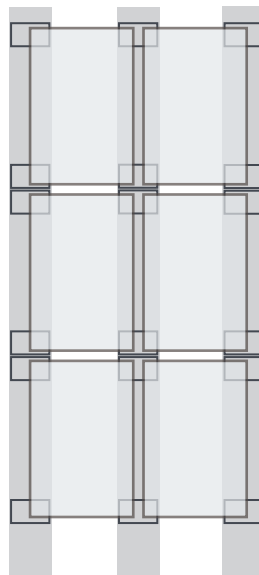

Module support „ECO 0° Standard“
Art. Nr.: 77.501.037

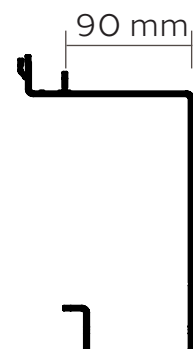

5. Mounting the supports „Standard“

5.3 Installing module supports



Interlocking the two rear module supports

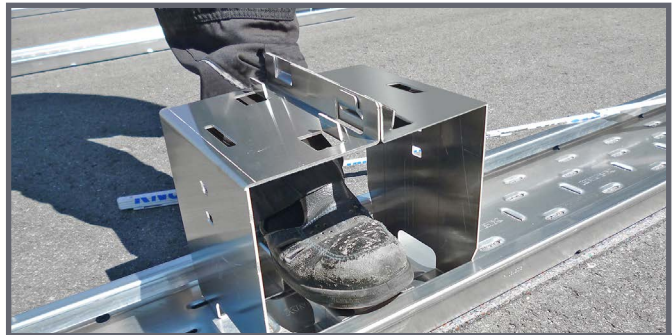

Clicking in the module supports



Fully assembled module supports for the first row of modules

It is recommended that the first row of modules including modules is installed completely to prevent the floor rails from slipping during further installation.

In order to prevent the supports from slipping, it is recommended that fixing plates are fitted at the end of the module array for roof pitches of 10° or more, provided the ground rails are laid in the direction of the slope. Additional fixing plates may be required for large module arrays or steep roof pitches. The exact positioning is specified in the respective installation plans.

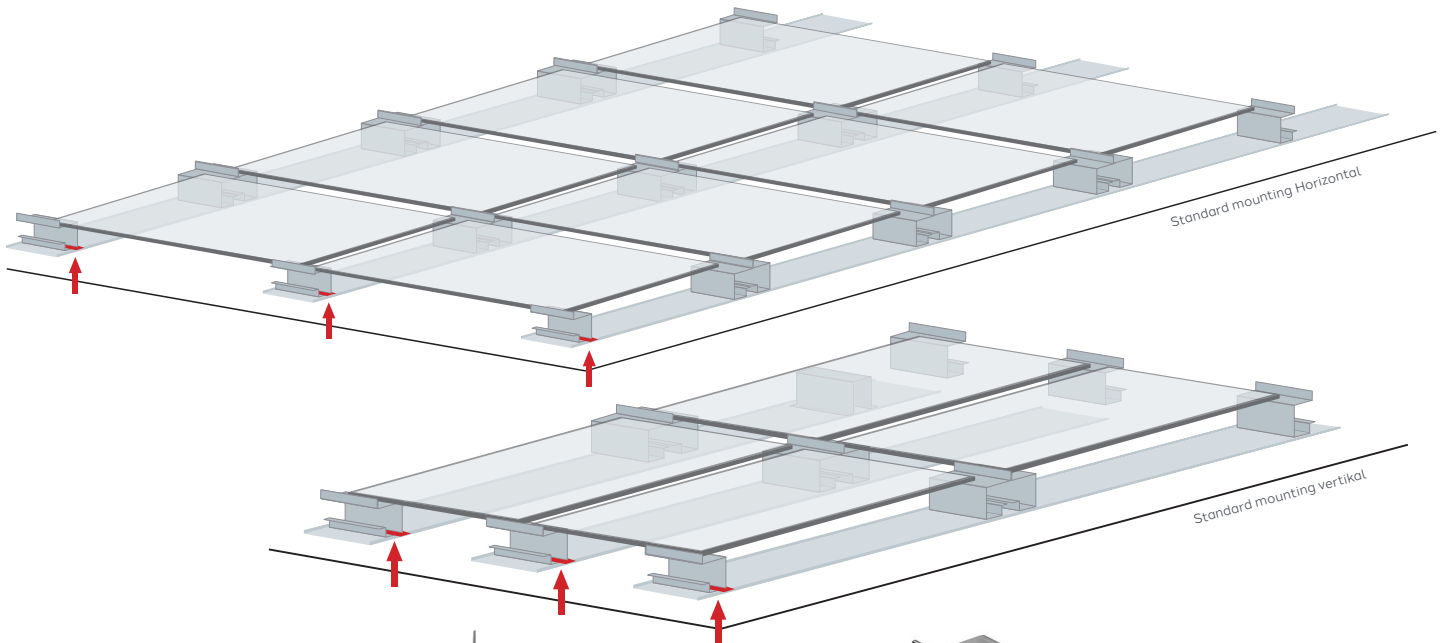

Duraklick mounting plate

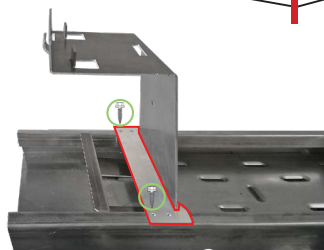

Mounting plate to prevent the supports from slipping.

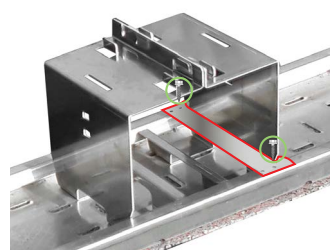

$>13^\circ = 2x$

For roof pitches over 13° , the use of double supports are recommended in order to avoid buckling under high snow loads.

6. Mounting the module supports “Optimum clamping”

6. Optimum clamping for high snow and wind loads

With our new Duraklick ECO 0° support for optimum clamping, we have the option with the ECO 0° to clamp the modules in the optimum position specified by the module manufacturer to ensure high snow and wind loads. The prerequisite for this is vertical installation of the modules at a maximum roof pitch of 10°.

6.1 Calibrate

Measure the positions of the module supports:

The optimum position of the module supports is specified by the module manufacturer in the respective installation instructions. We recommend a distance of 10-20 mm between the modules.



Calibrating the module support positions

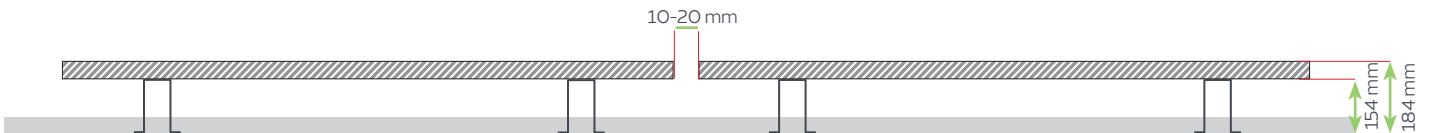

**Module support
“ECO 0° Optimal”**
Support for optimum
clamping.
Art. No.: 77.501.079

Mounting Vertikal

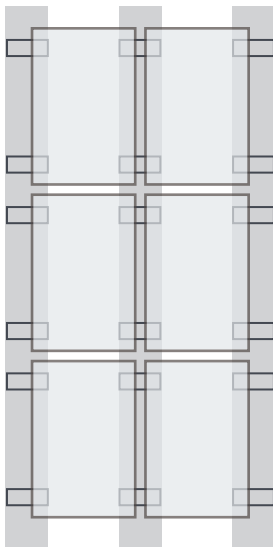

6.2 Inserting the string cable

Attention: the floor rails can be used as a cable duct. The string cables should be laid before the module supports are clicked

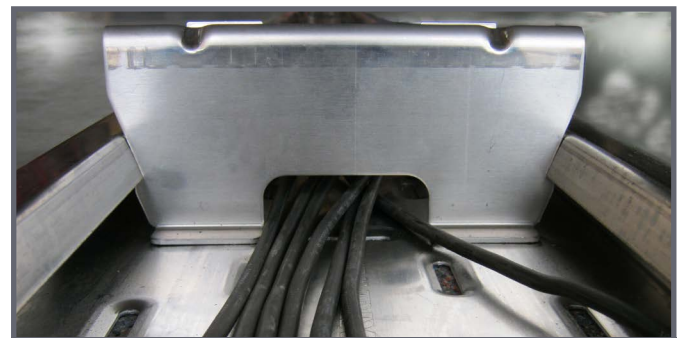

Floor rail used as a cable duct for the string cables

6. Mounting the module supports “Optimum clamping”

6.3 Installing module supports



Fully assembled module supports for the first row of modules



Fully assembled first row of modules

It is recommended that the first row of modules including modules is installed completely to prevent the floor rails from slipping during further installation.

ECO 0° with clamping in the optimum range specified by the module manufacturer.

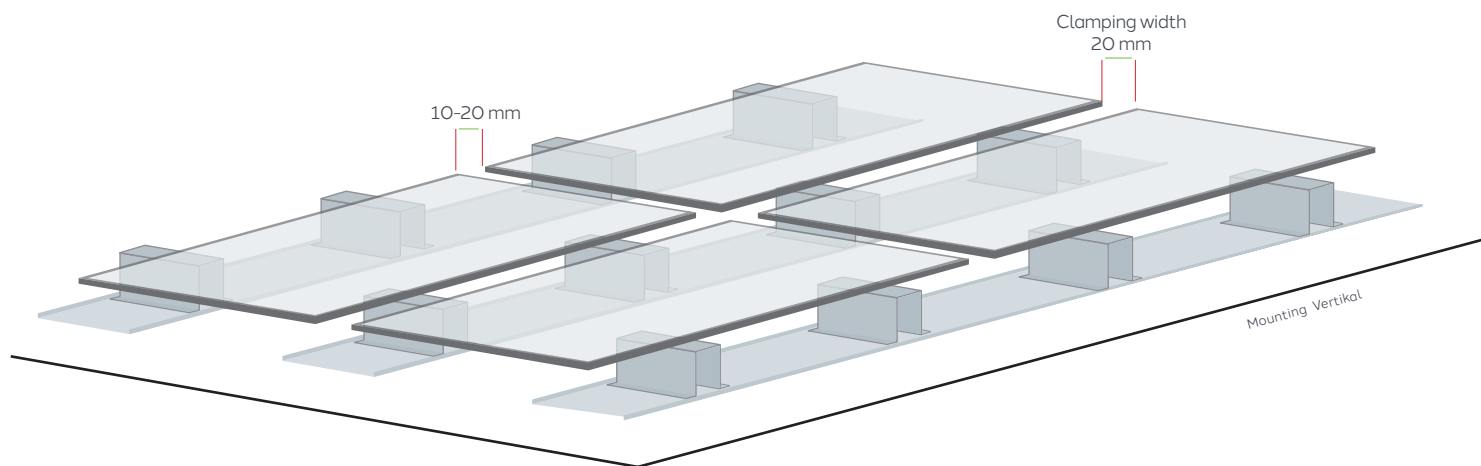

7. Special solution “6-point support/clamping”

Special “6-point support/clamping” solution for extremely high snow and wind loads

For extreme locations with exceptionally high snow and wind loads, we offer the option of clamping the modules at six points with our Duraklick ECO 0°. This allows us to transfer extremely high snow and wind loads to the substructure. It is also ideal for supporting PV modules with weaker module frames over a large area and, thanks to the stable and cohesive bond, can also be used for higher roof pitches. The modules must be mounted vertically.

7.1 Calibrate



Calibrating the module support positions

Measure the positions of the module supports. The first and last support must be mounted at least 150 mm from the end of the floor rail.

7.2 Inserting the string cable



Floor rail used as a cable duct for the string cables

Attention: the floor rails can be used as a cable duct. The string cables should be laid before the module supports are clicked.

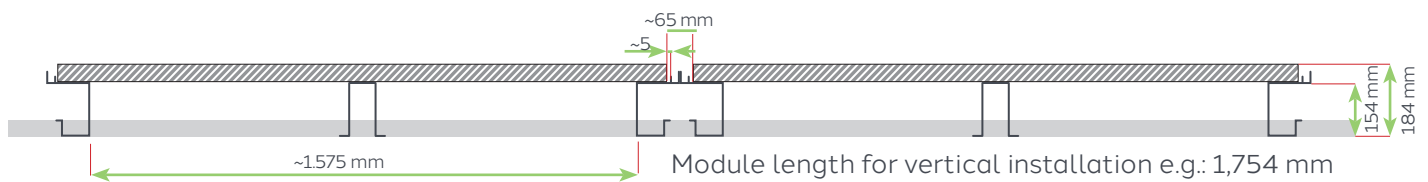

Distance dimension = module length/width minus 90 mm, minus 90 mm

“6 point support” mounting

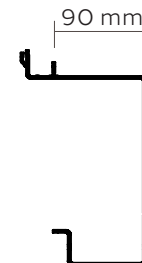
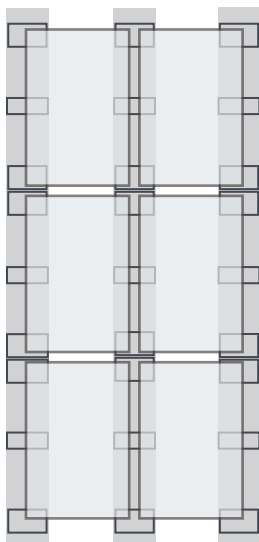

Module support
„ECO 0° Standard“
Art. Nr.: 77.501.037



Module support
„ECO 0° Optimal“
as center support
for 6-point
support/clamping.
Art. Nr.: 77.501.079

7. Special solution “6-point support/clamping”

7.3 Installing module supports

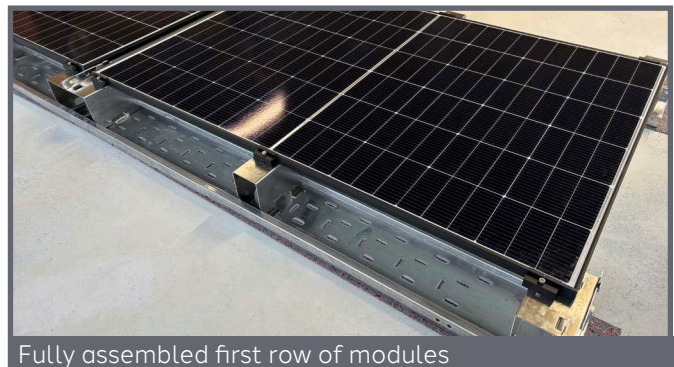
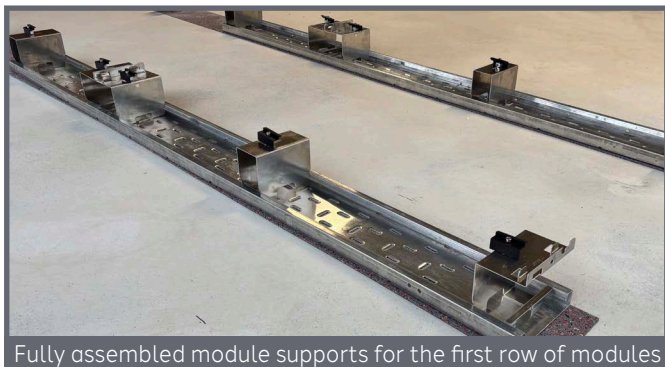
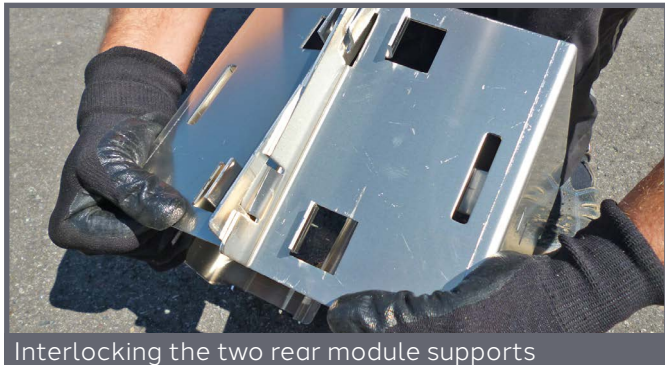

It is recommended that the first row of modules including modules is installed completely to prevent the floor rails from slipping during further installation.

ECO 0° with 6-point support/clamping for absorbing extremely high wind and snow loads.

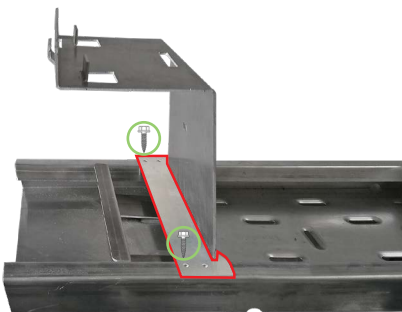
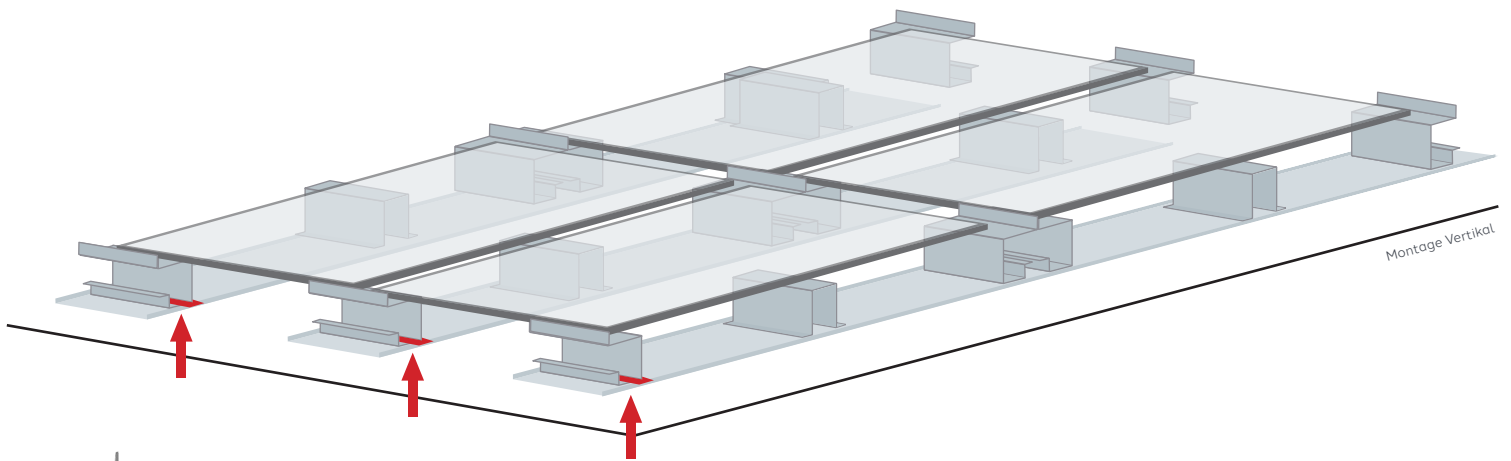



To prevent the supports from slipping, fixing plates are recommended at the end of the module array from a roof pitch of 10°.

8. Installing the modules

Ballasting

If ballasting of the floor rails is required according to the statics, this must be carried out before the modules are fixed. The specified ballast values must be adhered to!



 **The ballast values provided are mandatory values.** 

8.1 Inserting the one-piece Duraklick end clamp

On the first row of modules, first insert the module end clamps into the front and rear module support of the side to be started.

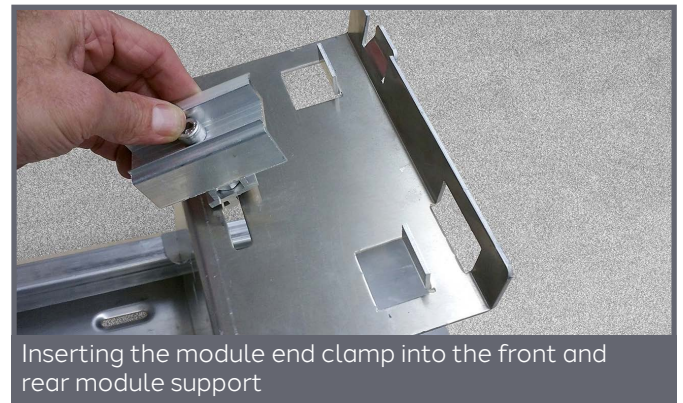

8. Installing the modules

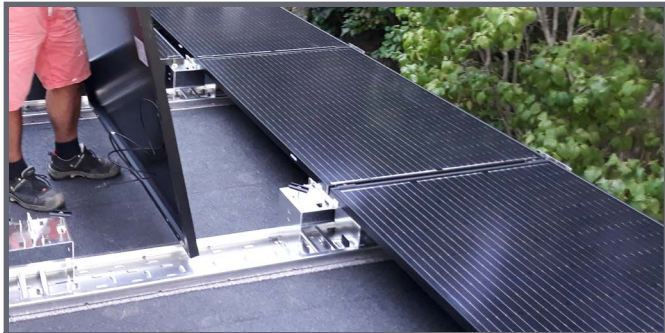

Installing the photovoltaic module

8.2 Inserting modules

You can start on the right or left.
Place the first module on the module supports.

Ensure that the module frame rests on the entire surface of the module support.

If the modules are inserted close to the lugs, the distance between the modules is automatically approx. 60 mm for rear ventilation!

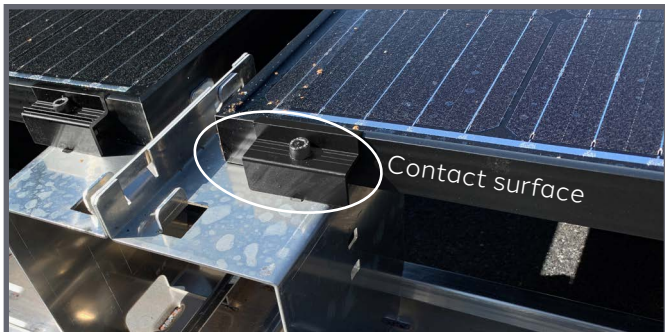

Distance 20 mm and contact surface

8.3 Inserting the module center clamps

Click the module center clamps into the module supports and screw them in lightly.



Inserting the module center clamp into the module supports

8.4 Attaching the cabling

Ensure that the string cables are installed and the modules are connected to each other. Otherwise the backs of the modules can no longer be reached.

The string cables can be laid in the recess the recess in the module support and secured with cable ties.



Recesses for cable routing

8. Installing the modules

8.5 Fastening modules

All module center terminals and module end terminals must be tightened with a 6 mm Allen key. Tightening torque min. 8 - 10 Nm. The module manufacturer's tightening torques apply!

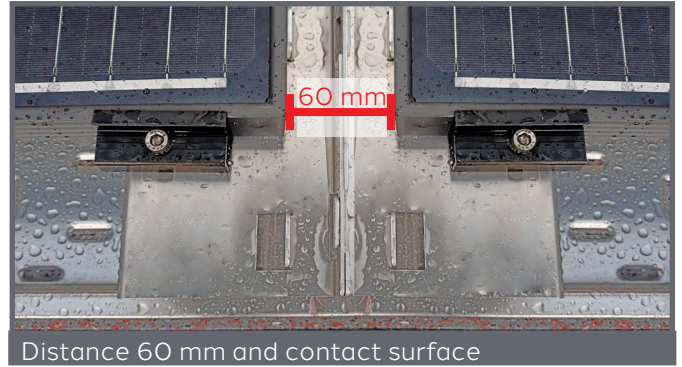

8.6 First row of modules complete mount

Repeat all work steps until the first row of modules is installed. The first row of modules should be installed completely to prevent the floor rails from slipping.



Wind hazard!

If installation is interrupted or stopped, all modules or rows must be fully installed. ATTENTION: Wind attack! Loose rails must be secured or weighted down!





7. Control

Once the modules have been installed, the entire system must be checked for strength:

- ▶ Check the fastening of the module clamps.
- ▶ Check the entire construction for stability and strength.
- ▶ Check screw and clamp connections

Accessories

For our systems we offer the following accessories:

HSS fall protection system

Horizontal rail system for up to 4 people
 DIN EN 795:2012 Type D + E CEN/TS 16415:2013
 The certified fall arrest system is a flexible and economical fall protection system that can be Duraklick substructures (including existing ones) can be installed.

For more safety when working on roofs!

The system has been tested and approved by:

DEKRA Testing and Certification GmbH
 Dinnendahlstr. 9
 44809 Bochum
 Zertifikat Nr.: ZPB03522



Exclusion of liability

The manufacturer will not be held liable for the use of the mounting system for purposes other than those intended.

Warranty conditions

The terms provided by law shall apply.

Manufacturer information

The Duraklick PV mounting system Eco O° is manufactured by:

SOLTOP Energie GmbH
Lindauer Straße 15
D-88145 Hergatz
www.soltop-energie.eu



Duraklick



Warranty certificate

On all Duraklick mounting systems supplied by us you will receive

10 years durability guarantee on all parts.

If damage occurs during normal use and despite proper installation and handling, we will immediately replace the affected component within the warranty period.

The obligation to provide warranty service does not apply if the damage occurred in connection with exceptional stress (e.g. storm damage, exposure to instability of the substrate, special chemical or biological effects), unless it can be proven that the damage was not caused by this, but was essentially caused by a material or design defect. The installation and handling shall be governed by the technical the technical product descriptions and installation instructions supplied by us for the respective products, the legally prescribed or or generally accepted standards and principles of construction principles of construction as well as, if applicable, the plans, structural analyses and instructions prepared by us individually for the customer shall have priority.

The warranty is limited to the subsequent delivery of defective parts upon notification of the damage within the warranty period. Any statutory warranty or liability claims shall remain unaffected.

Insofar as a possible shorter service life is expressly stated for certain components in general or for a certain type of use, or replacement within a shorter period is provided for within the framework of plans individually drawn up by us, the warranty period shall be limited to this service life or period.

If the damage is covered by an insurance policy against storms and similar events (elementary insurance) or can be can usually be covered, there are no claims.

This warranty only substantiates claims by our contractual partner, through whom all warranty claims are to be processed. Claims may only be asserted by third parties if we agree to this. In all other respects, our General Terms and Conditions shall apply in their currently valid version.



For more information, please visit www.soltop-energie.ch & www.soltop-energie.eu

SOLTOP Energie AG
St. Gallerstrasse 3
CH-8353 Elgg
info@soltop-energie.ch

SOLTOP Energie GmbH
Lindauer Straße 15
D-88145 Hergatz
info@soltop-energie.eu

SOLTOP Energie SA
Rue des Sablons 8
CH-3960 Sierre
info.fr@soltop-energie.ch

SOLTOP Energie SA
Avenue Haldimand 41
CH-1400 Yverdon-les-Bains
info@soltop-energie.ch

Mounting system Roofprallel Eco 0° Assembly instruction

© SOLTOP Energie GmbH • Montageanleitung Eco 0° en. • Printed in Germany 02/2025 • Subject to change!



For more information, please visit www.soltop-energie.ch & www.soltop-energie.eu

SOLTOP Energie AG
St. Gallerstrasse 3
CH-8353 Elgg
info@soltop-energie.ch

SOLTOP Energie GmbH
Lindauer Straße 15
D-88145 Hergatz
info@soltop-energie.eu

SOLTOP Energie SA
Rue des Sablons 8
CH-3960 Sierre
info.fr@soltop-energie.ch

SOLTOP Energie SA
Avenue Haldimand 41
CH-1400 Yverdon-les-Bains
info@soltop-energie.ch