

PliaTherm AS EW_R2

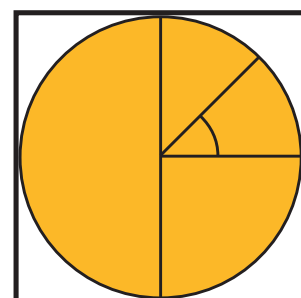
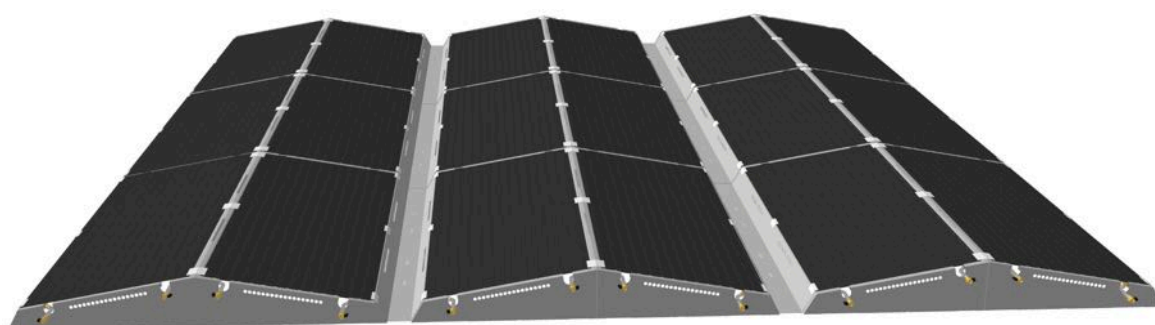
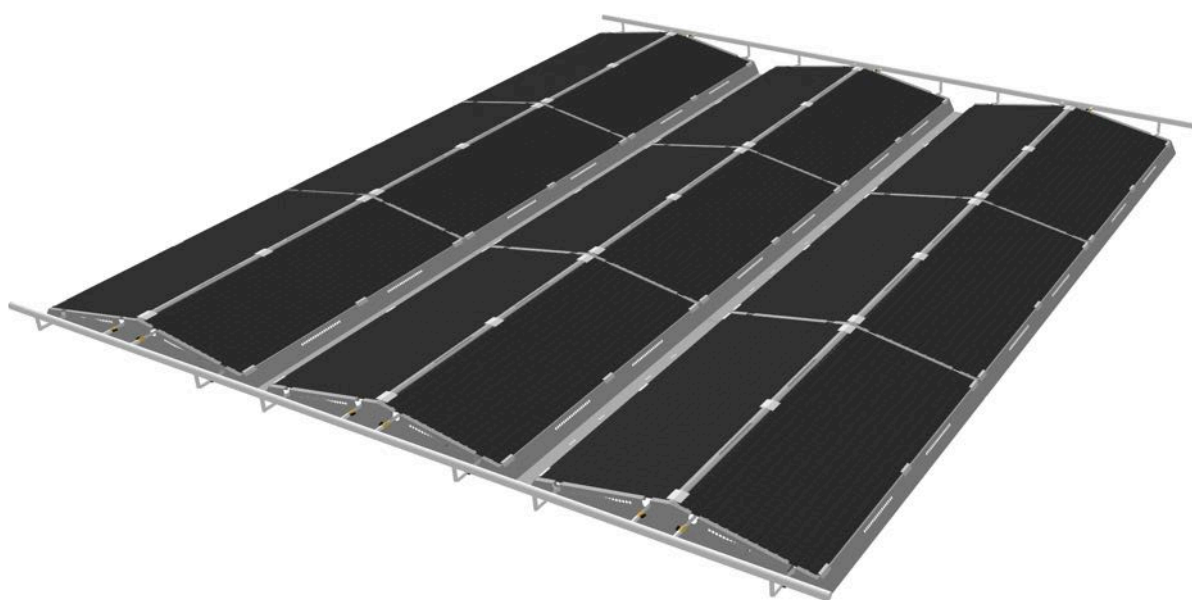

ENERGIE
SOLAIRE

1

2

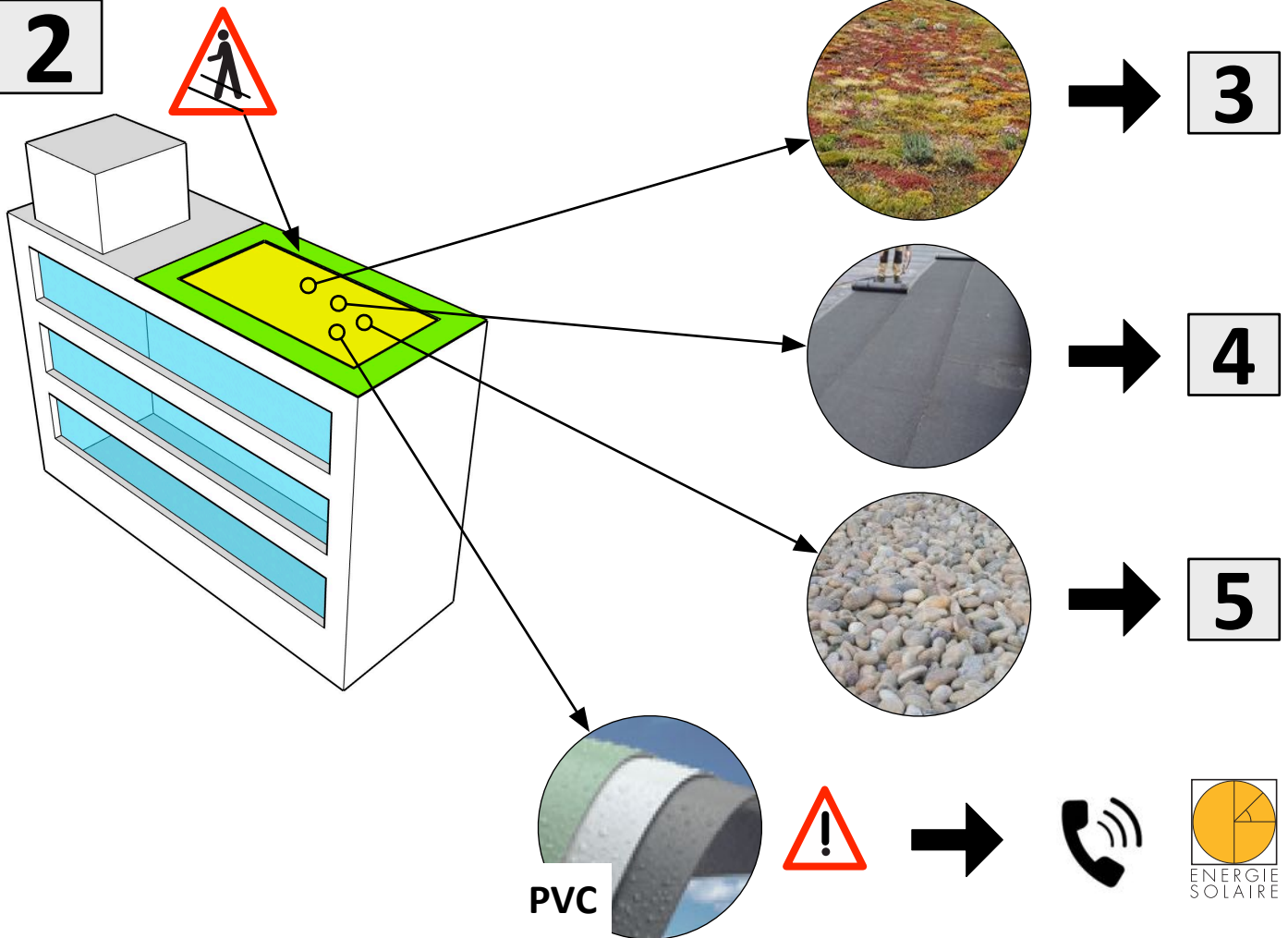

3



PLANTEX GOLD

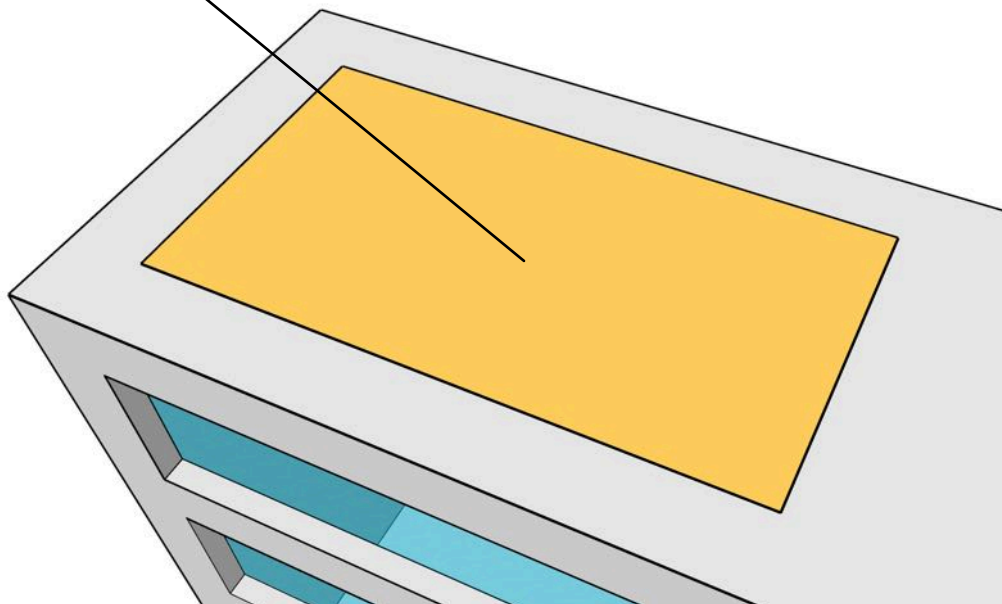

4



BEKA

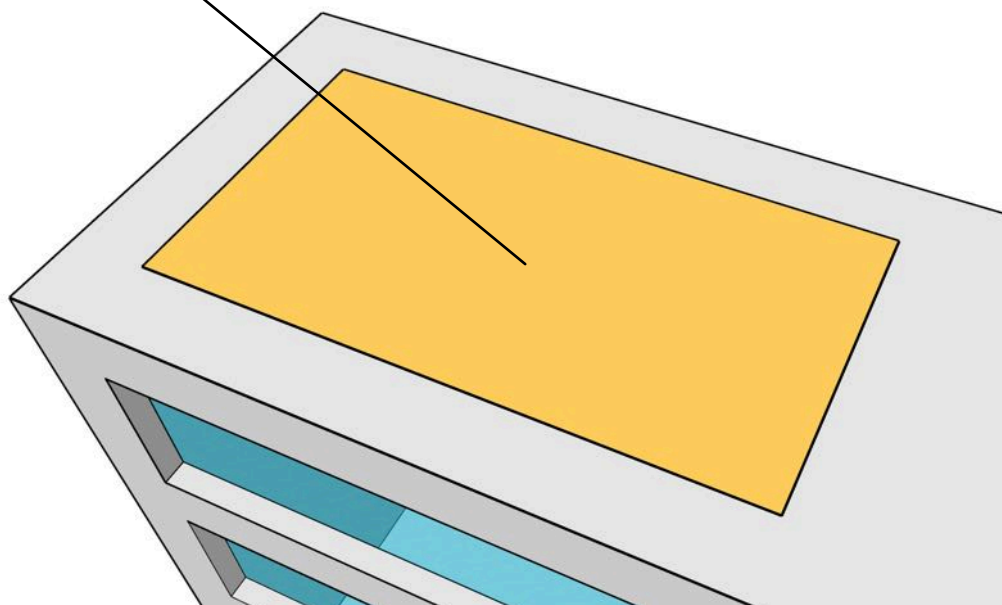

7

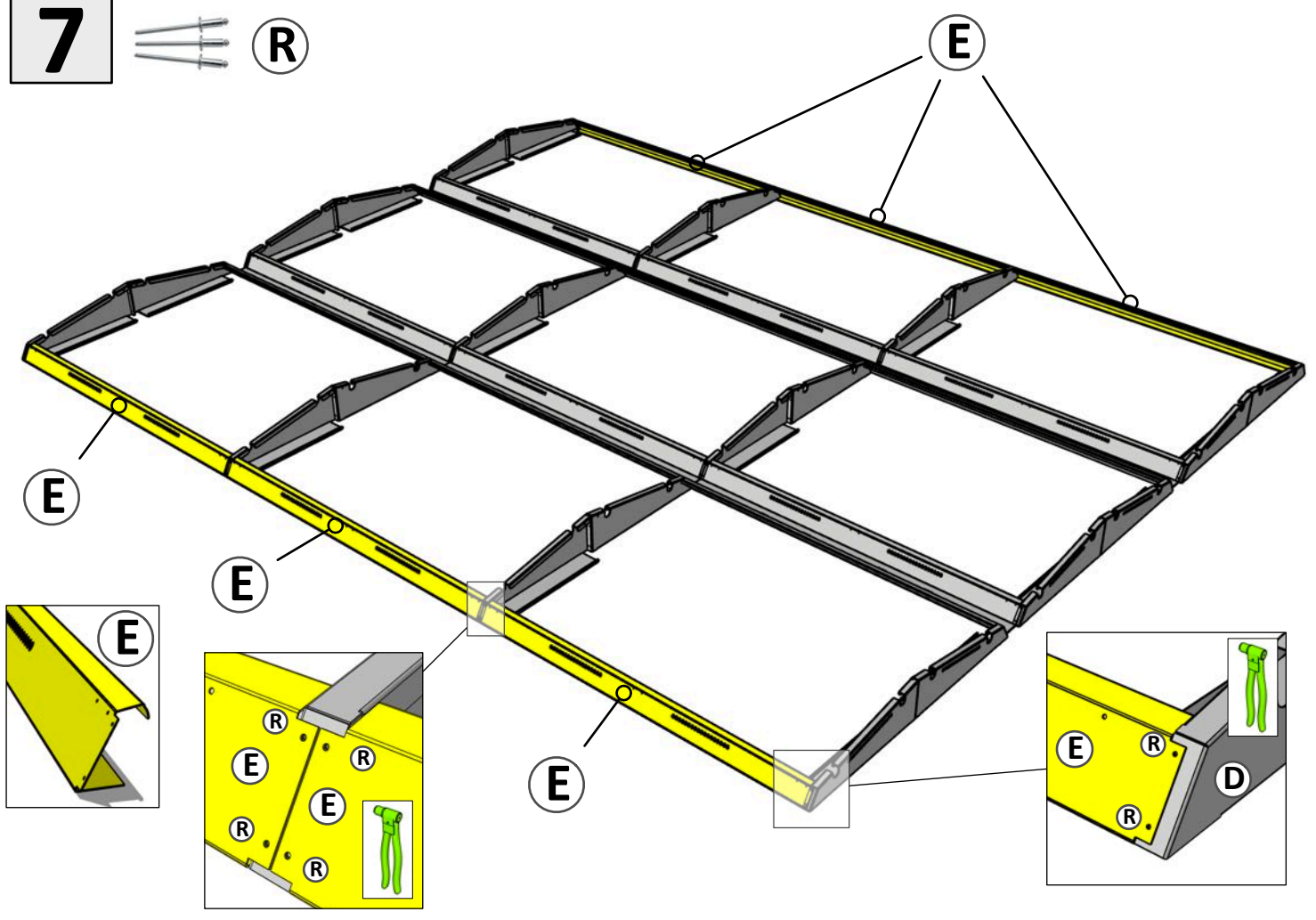

8

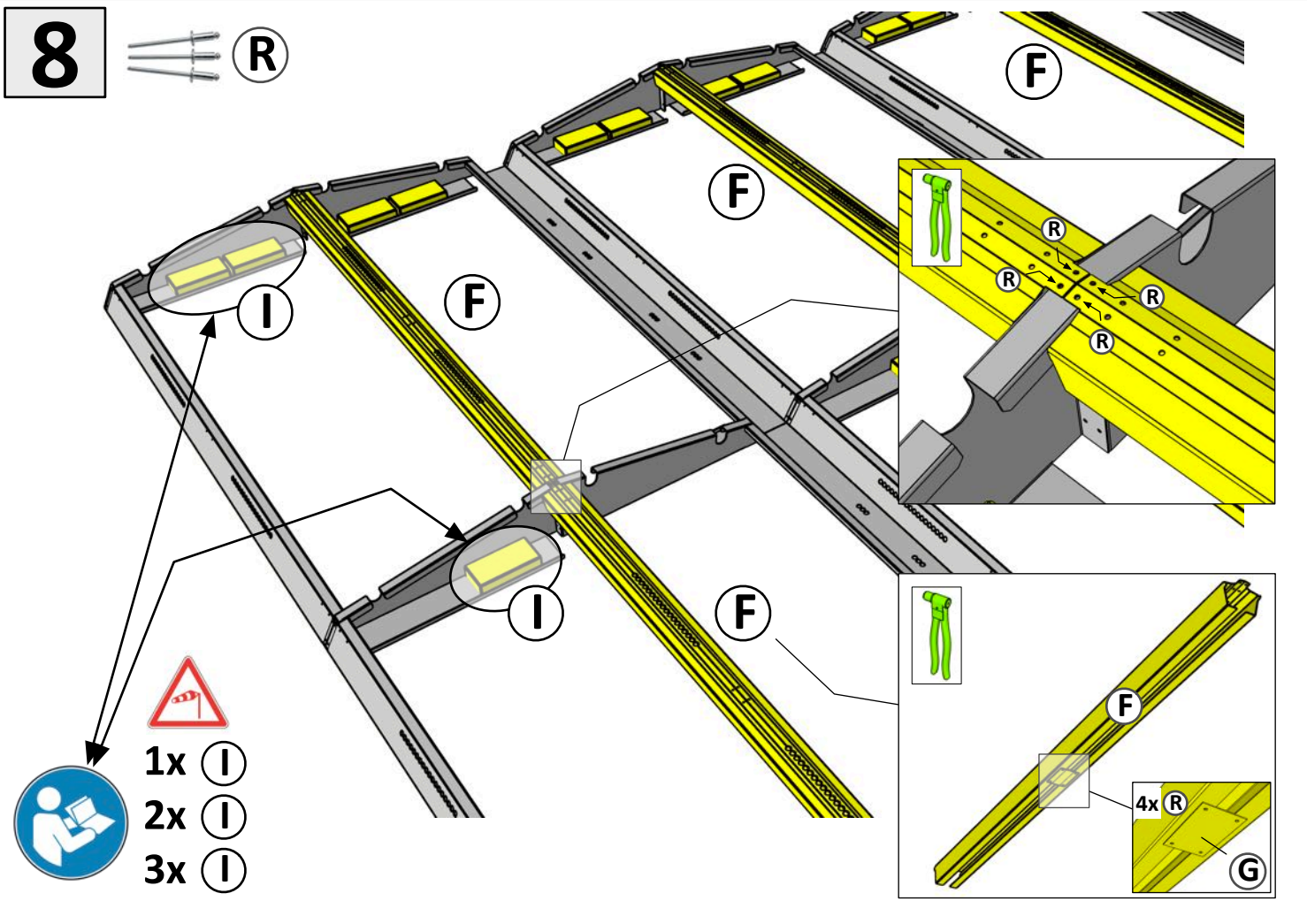

- 1x (I)
- 2x (I)
- 3x (I)

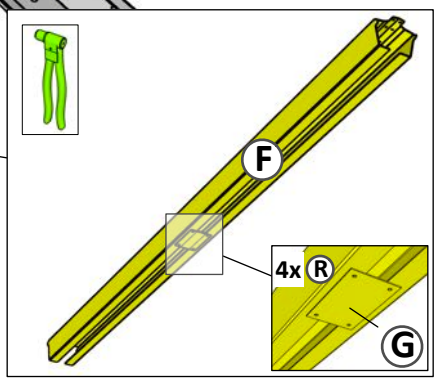
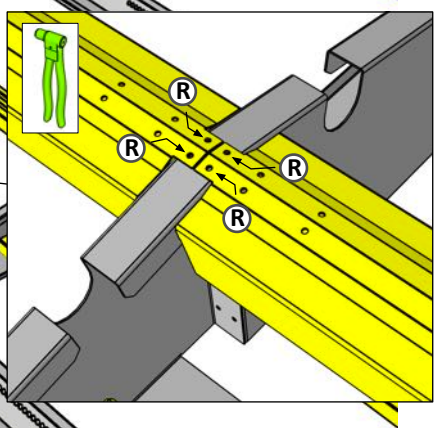

9

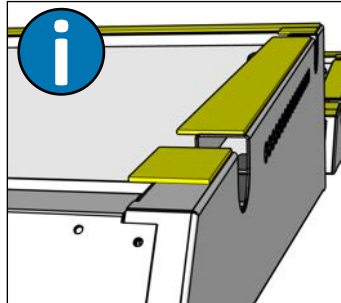
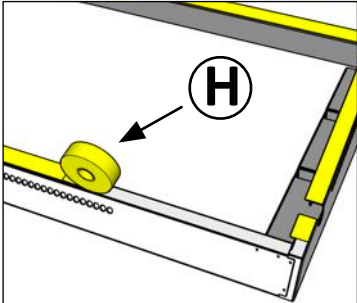
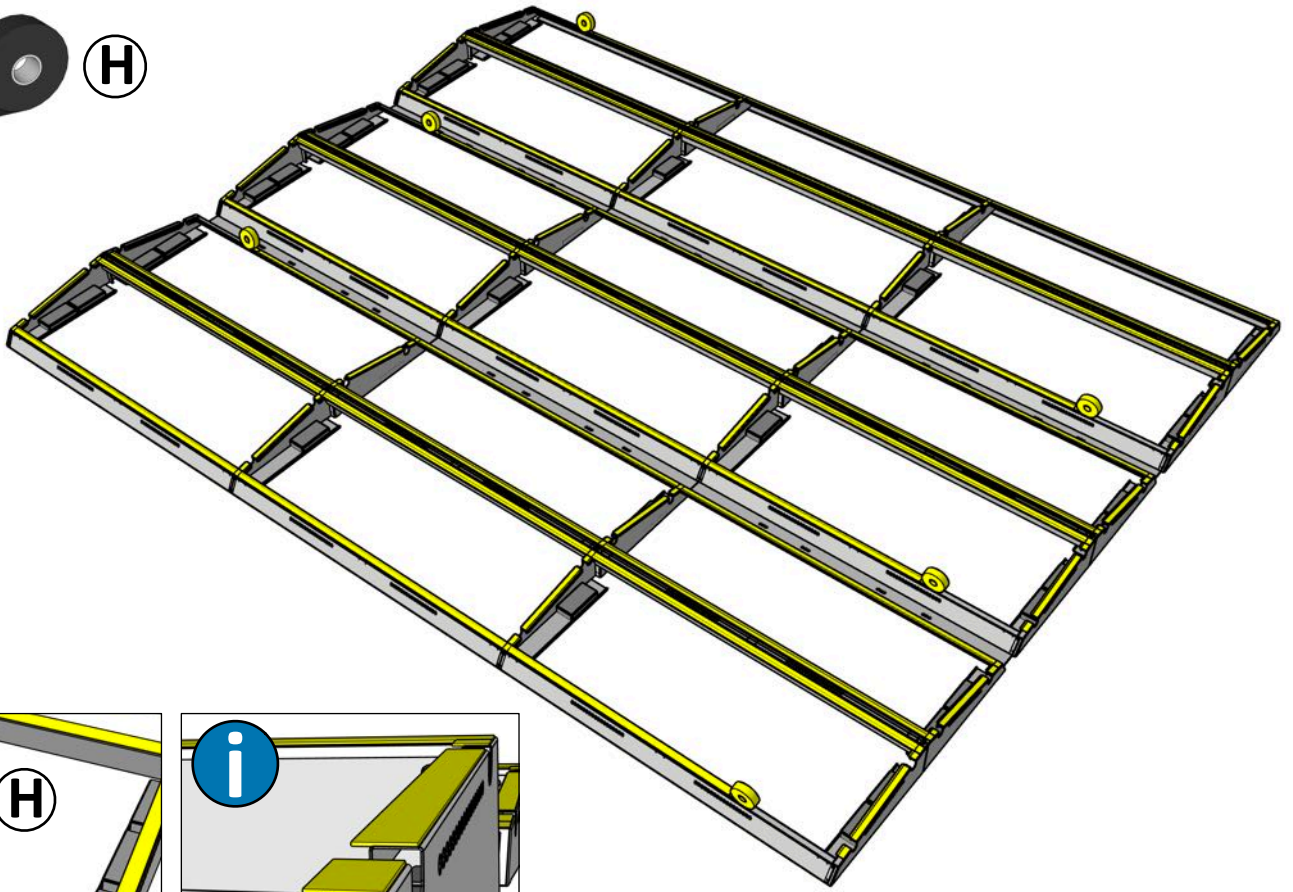

10

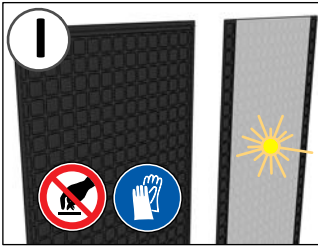

1° **K**
! 08.20.15RD.GRAISSE

2° **K**

3° 22 mm

4° Clic!
max 2 mm

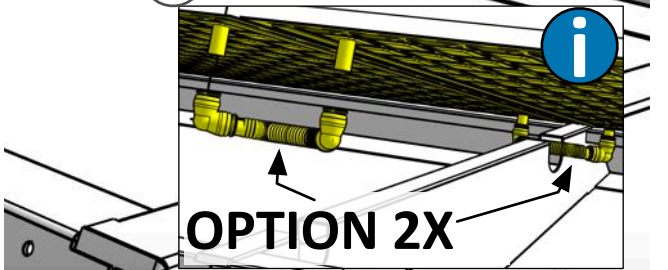
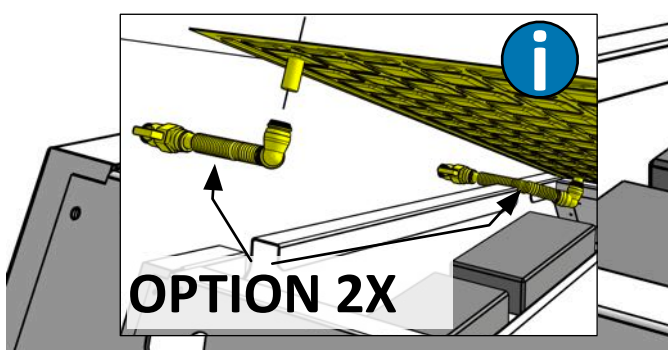
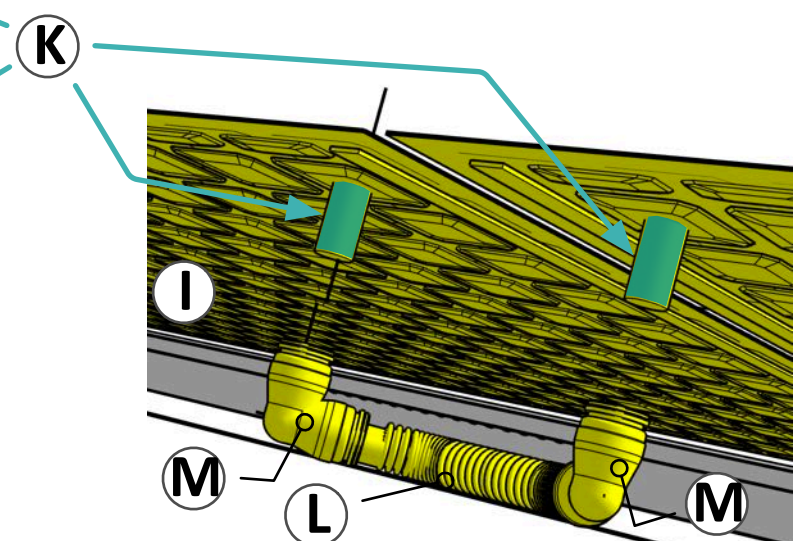
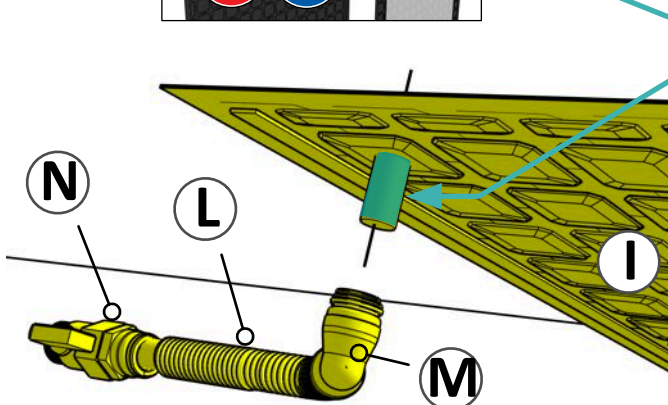

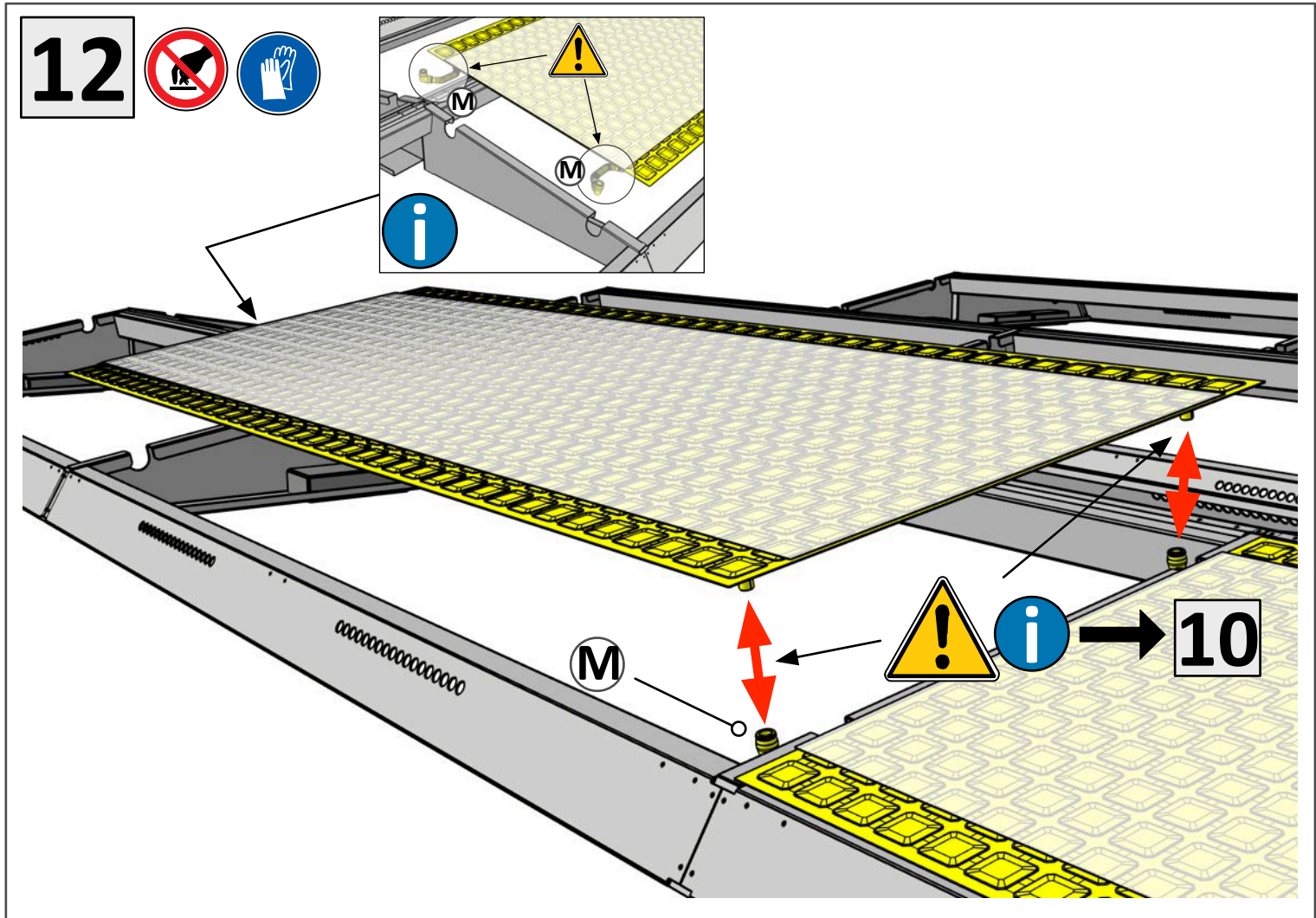
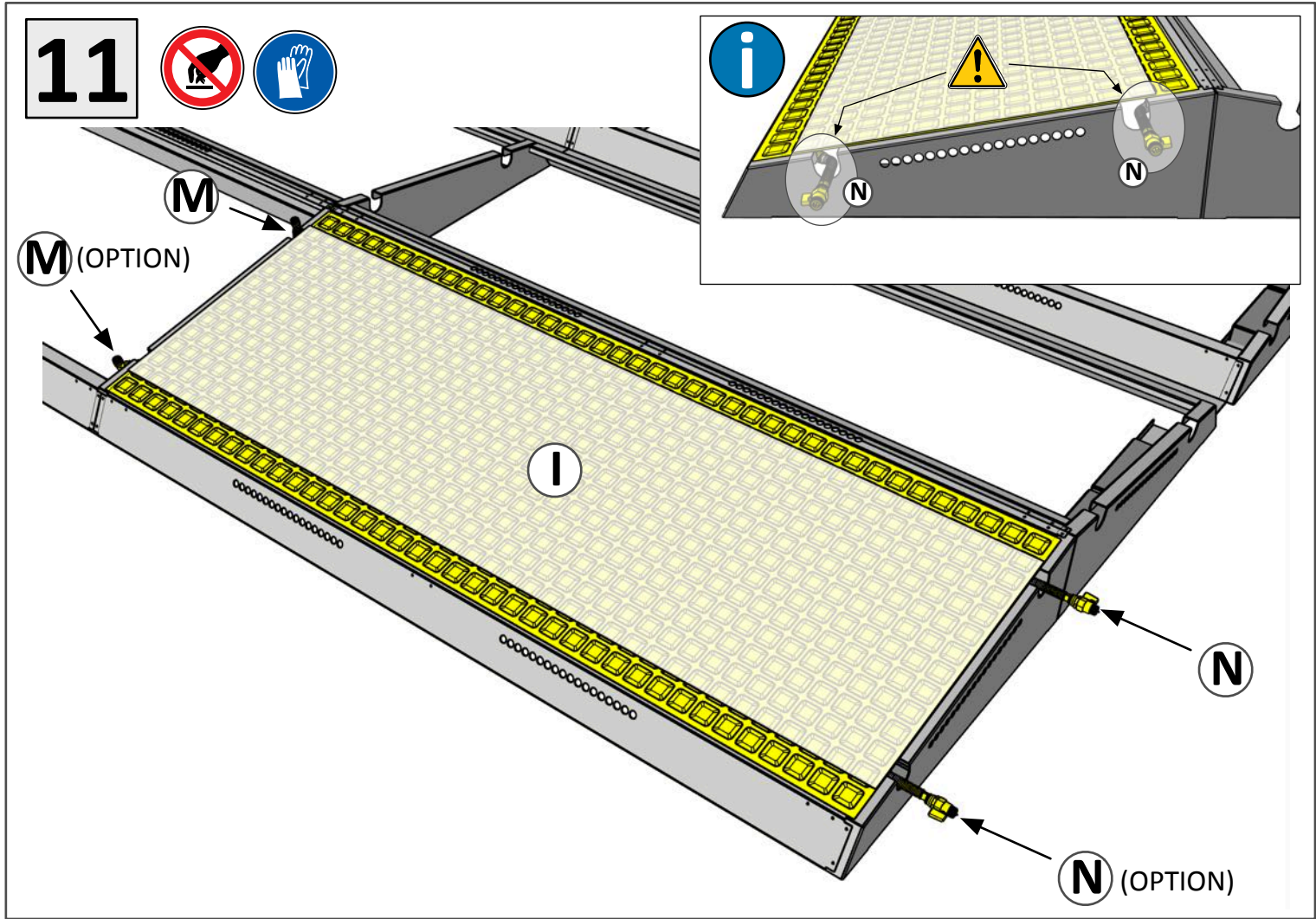

13

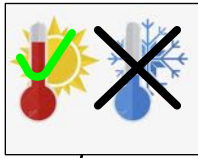

Pt1000 ? NO
YES

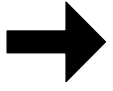

14

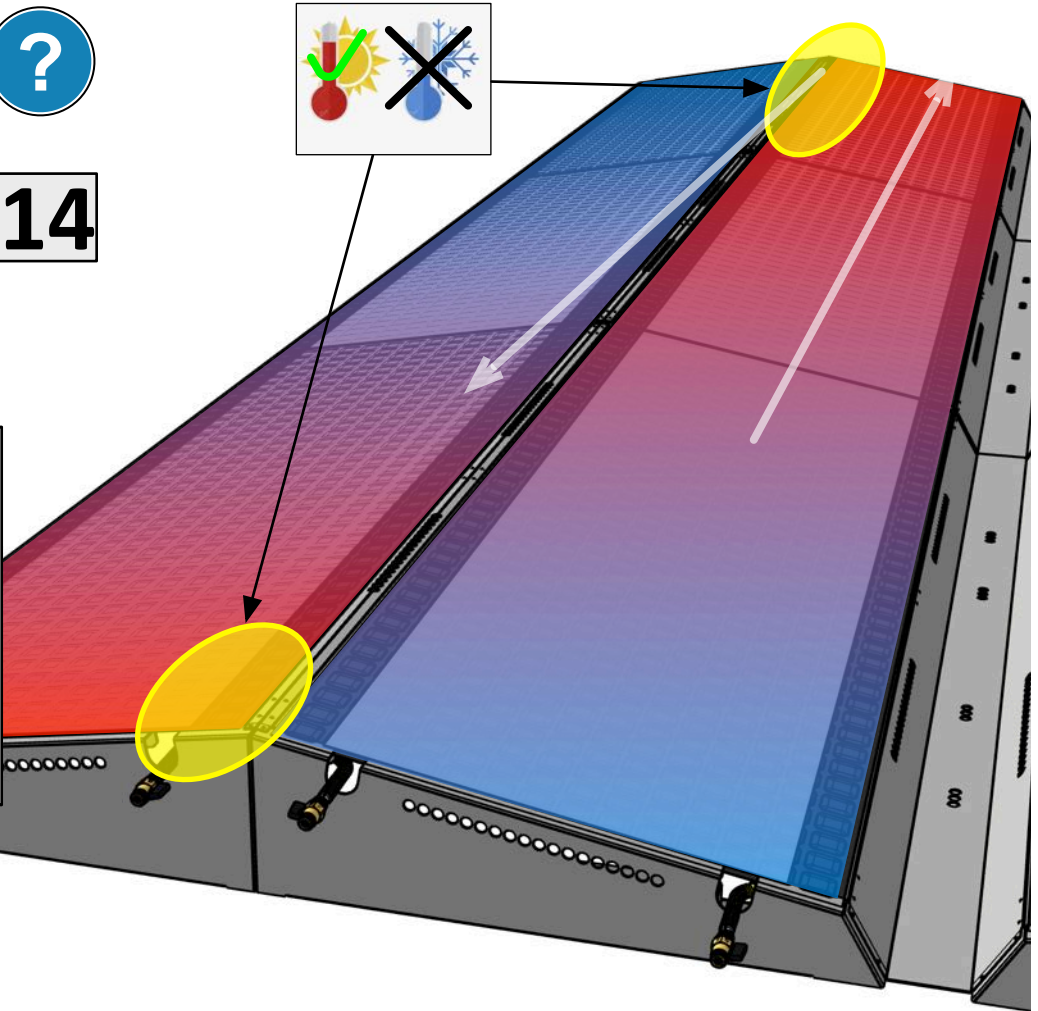
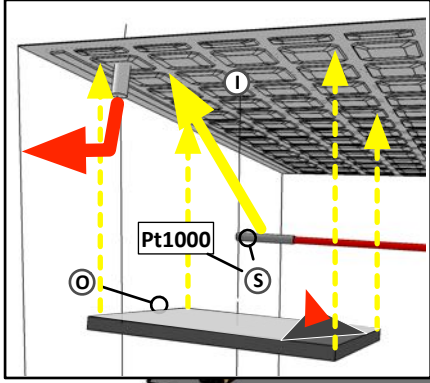
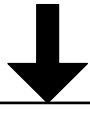

14

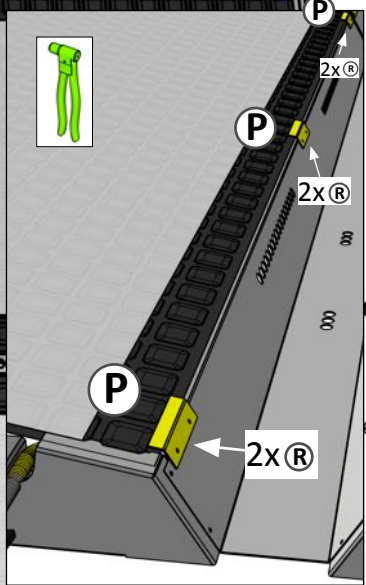
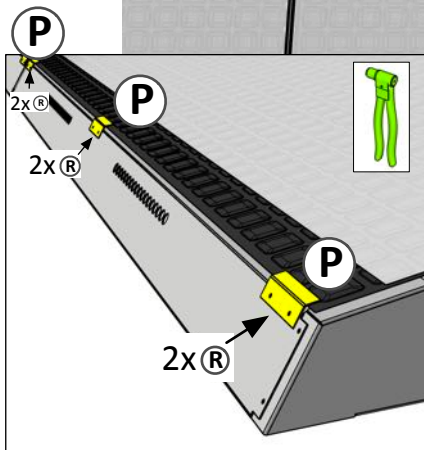
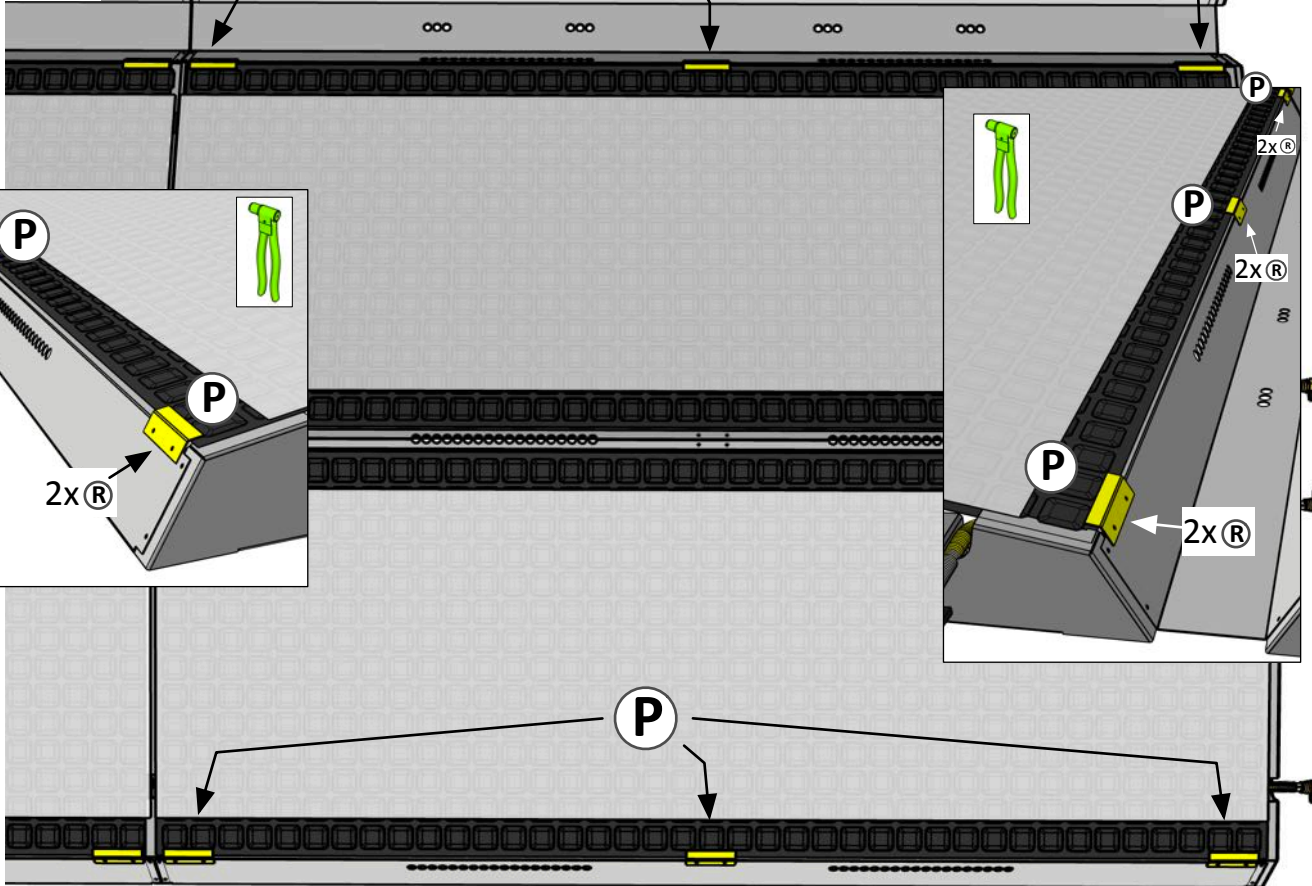

15

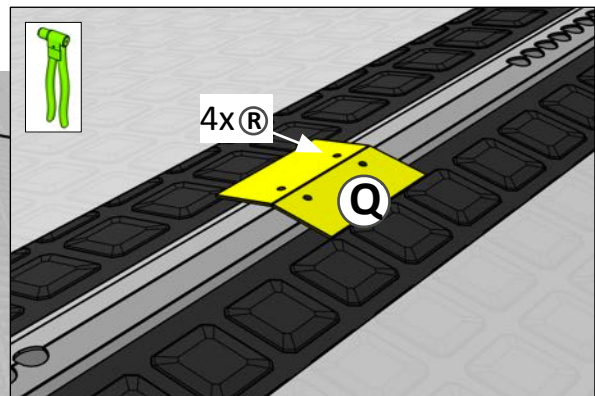
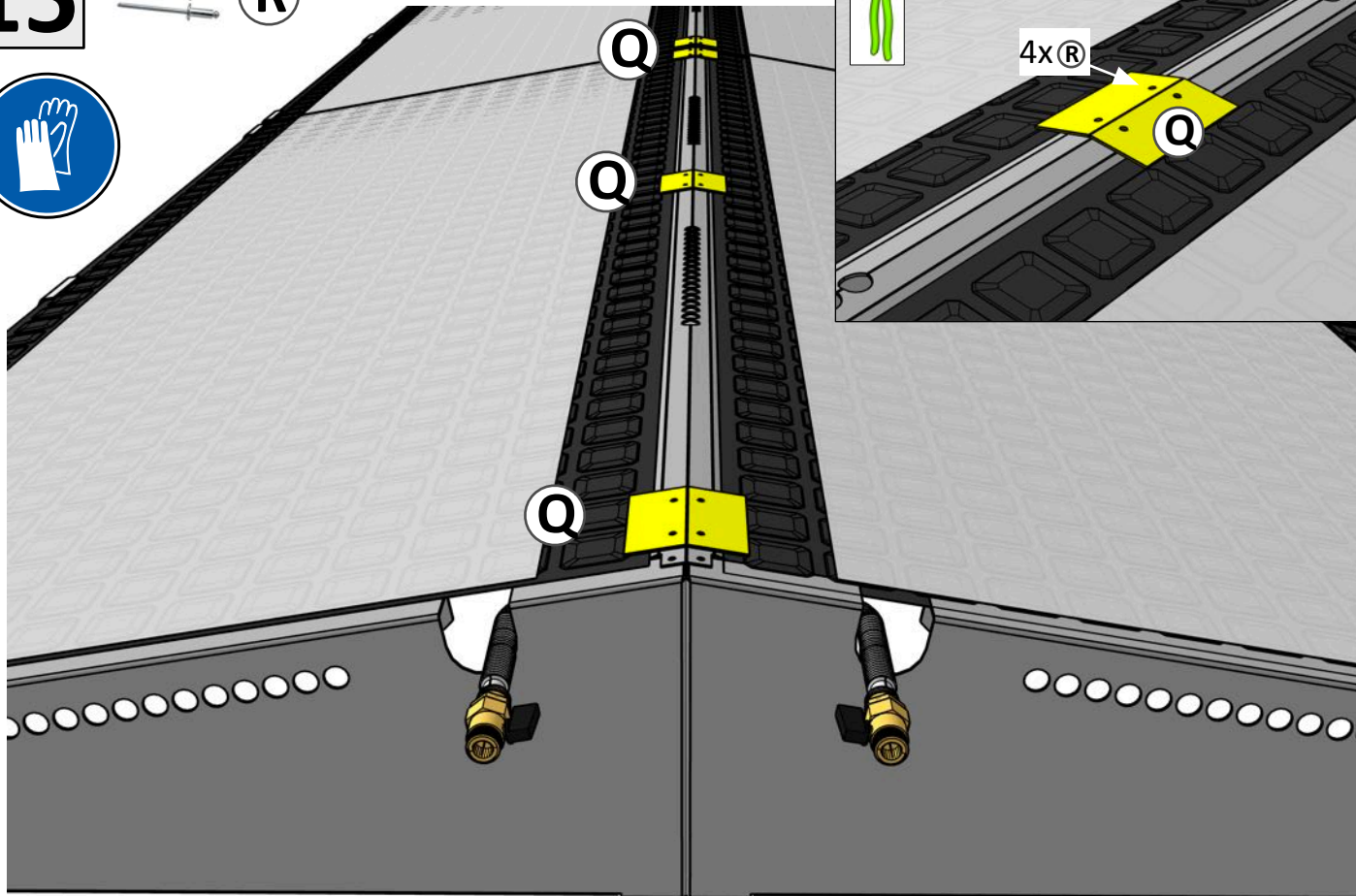

16

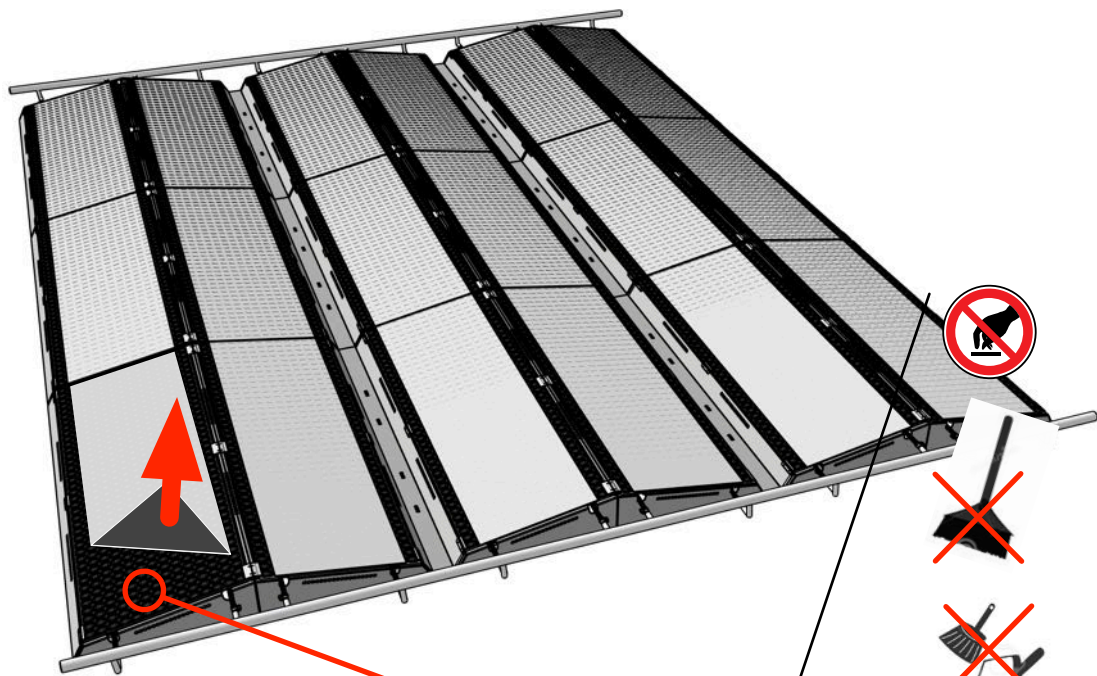

Entfernen Sie den Schutzfilm sofort nach der Montage der Solarkollektoren
 Retirer le film de protection immédiatement après le montage des capteurs solaires
 Remove the protective film immediately after mounting the solar collectors



17

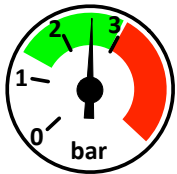

Max 3 bar

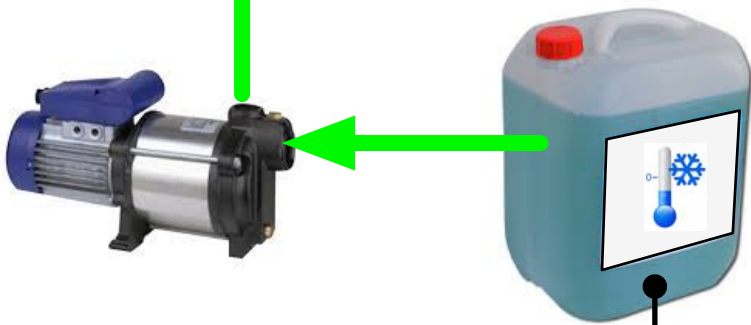
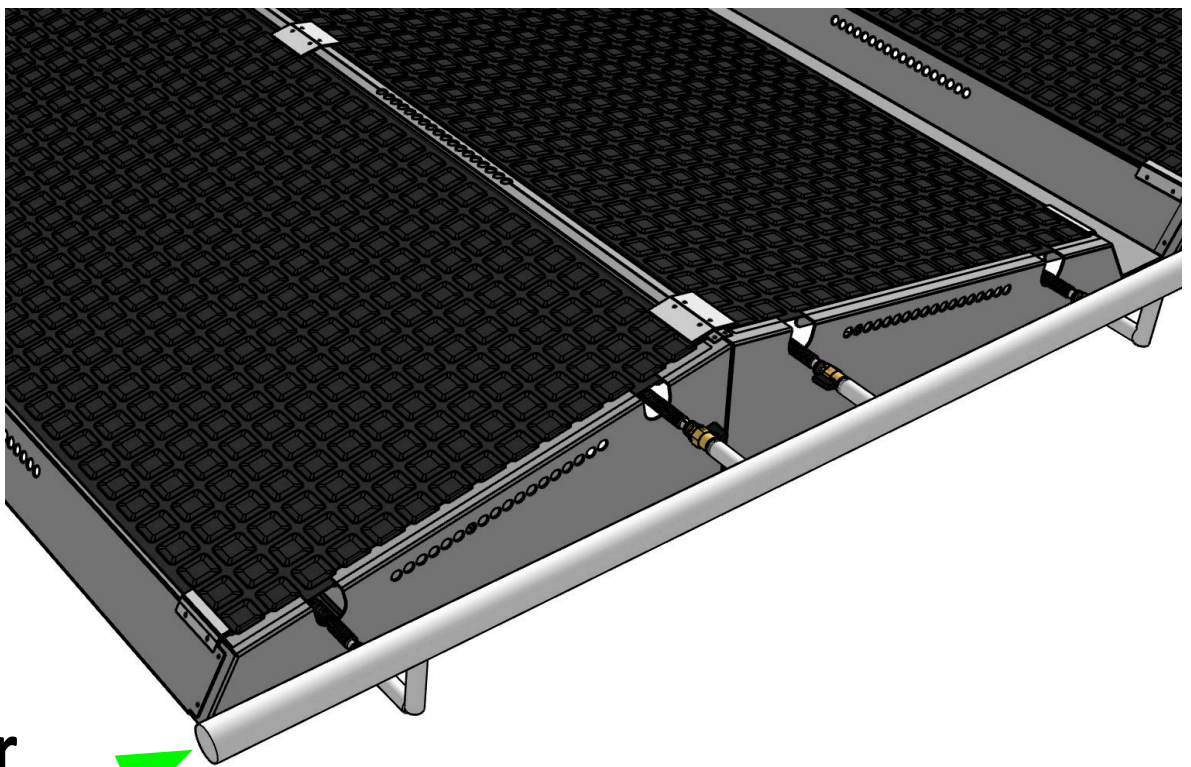

SICC BT 102 01



VDI 2035

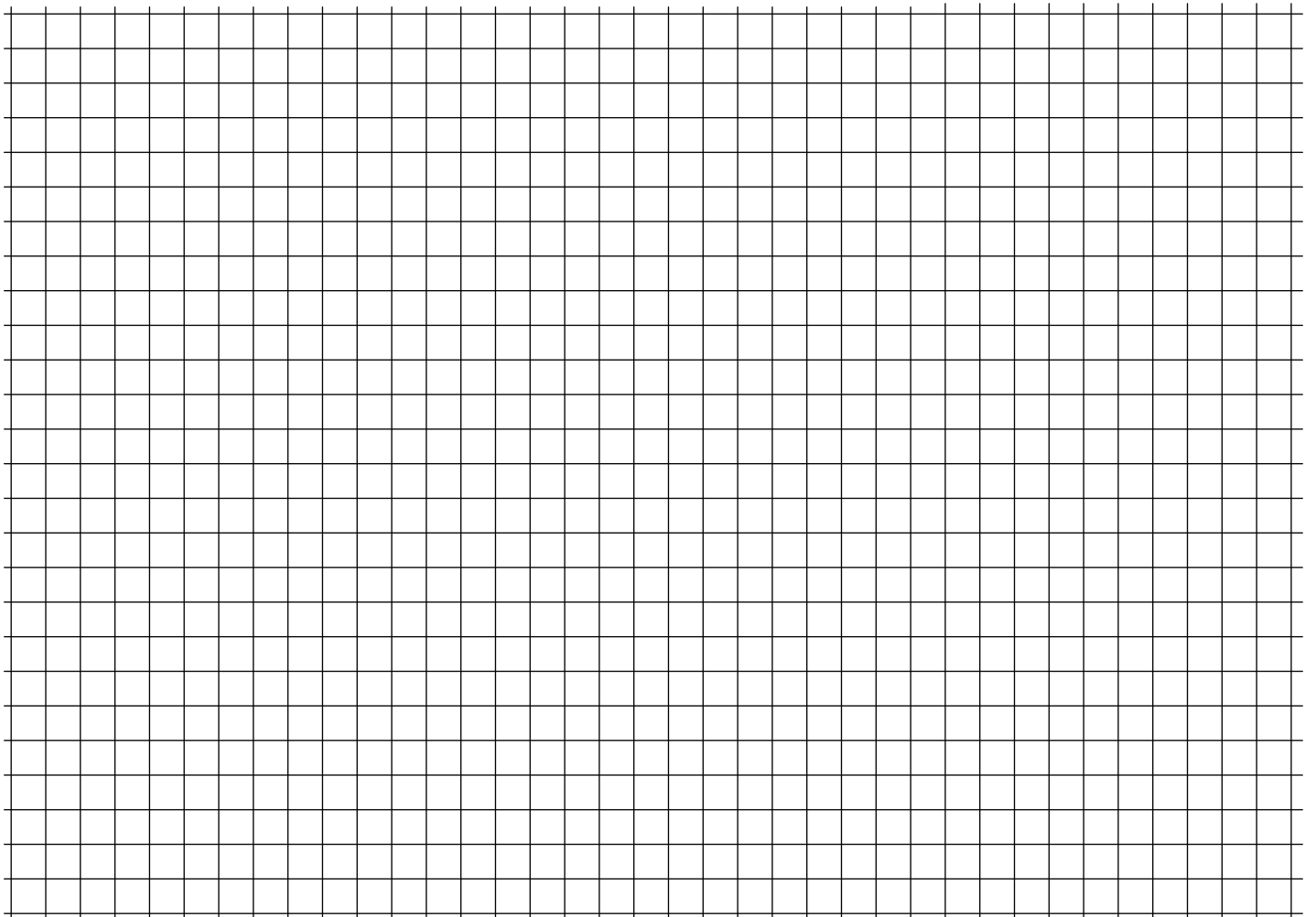
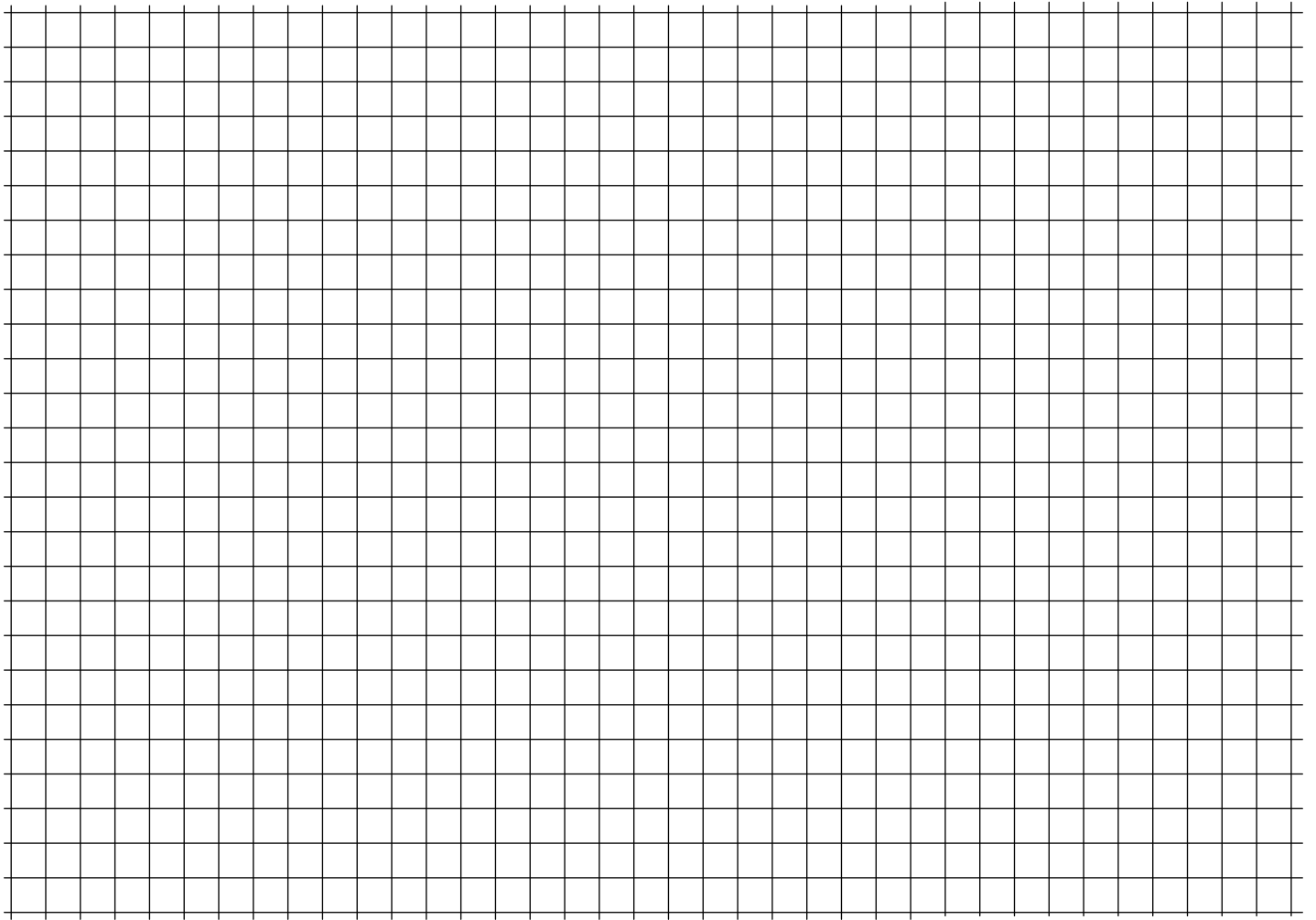



Contact :

Energie Solaire SA
ZI Ile Falcon
Rue des Sablons 8
Case postale 353
CH-3960 Sierre

Tél.: +41 27 451 13 20
Fax: +41 27 451 13 29

info@energie-solaire.com
www.energie-solaire.com